

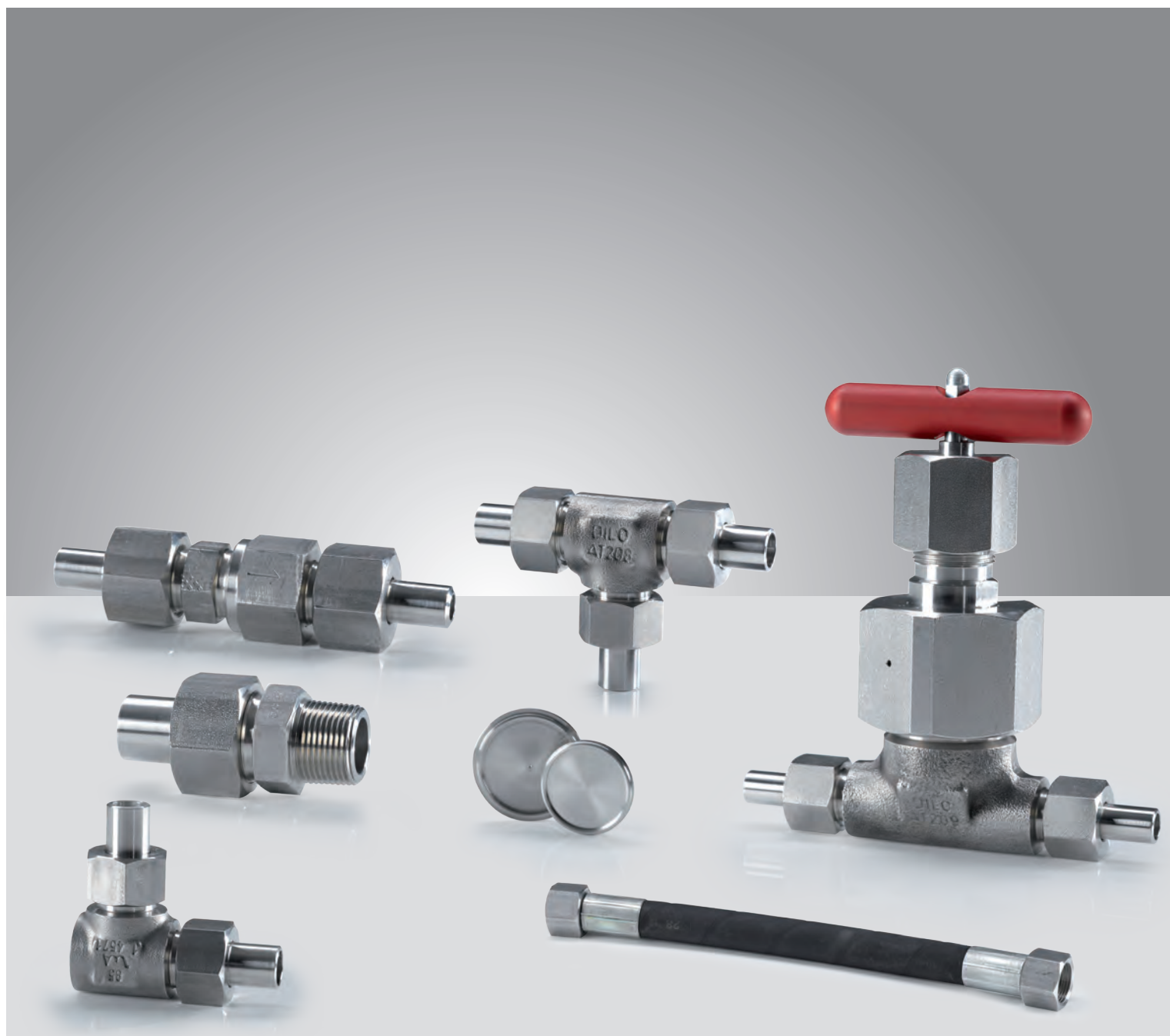

High pressure tube unions



DILO. Sustainably tight.

Made ■
in ■
Germany ■

Table of contents

■ General	04 – 16
<hr/>	
DILO unions for pressure ranges from 100 – 320 bar	
■ Straight unions	17 – 30
<hr/>	
■ Weld-on tube unions	18 – 20
■ Screw-in tube unions with metric, Whitworth- or NPT thread	21 – 29
■ Angle unions	31 – 38
<hr/>	
■ Angle weld-on unions	32 – 33
■ Angle screw-in unions with Whitworth thread	34 – 35
■ Throttlefree angle-swivel unions with Whitworth thread	36 – 37
■ Tee and L-unions	39 – 50
<hr/>	
■ Tee weld-on unions	40 – 41
■ Tee /L-screw-in unions with Whitworth thread	42 – 45
■ Throttlefree Tee /L-swivel unions with Whitworth thread	46 – 49
■ Gauge connecting unions	51 – 53
<hr/>	
■ Superheated steam unions	55 – 63
<hr/>	
■ Accessories for unions	65 – 68
<hr/>	
■ Copper seals	66 – 68
■ Valves	69 – 74
<hr/>	
■ Manual blocking valves	70 – 71
■ Non-return valves	72 – 74
■ Blanking disks	75 – 79
<hr/>	
■ High pressure hoses	81 – 84
<hr/>	
■ DILO soldering unions for pressures up to PN64	85 – 92



Do you have to handle high pressures, extreme temperatures, aggressive media or hot vapours with high process reliability? Here are DILO's high pressure tube unions! Our high pressure tube unions remain hermetically sealed even under critical operating conditions. The secret lies in the high quality metal-to-metal sealing principle developed by DILO. The high pressure tube unions are sealed without any intermediate seal compound. The seal is obtained by direct contact of the tongue and groove sealing surface.

■ General

■ DILO seal principle	05
■ Material standards	06
■ Marking / Identification	07
■ Welding procedures	08
■ Technical data of threads	09
■ Mounting Instructions	10
■ Fittings for pressure ranges up to PN 640 and PN 1000 bar	13
■ Torque table	14
■ Pressure stage table	15
■ Quality assurance	16

DILO seal principle

DILO is a seal principle without intermediate seal in the form of groove and tongue with little depth of immersion. This principle guarantees permanent tightness at high static and dynamic alternating stresses which might result from vacuum and pressure in connection with high temperatures and vibrations inside the tubing systems.

Sealing in accordance with the DILO principle is effected by direct contact of the sealing profiles of the groove and tongue parts. The different radii of curvature of groove and tongue are in a certain relation to each other. Thus, two ring-shaped sealing areas are produced which create high stability.

The additional braking surface prevents plastic deformations at the ring-shaped sealing areas.

DILO fittings are easy to assemble and require no maintenance. They can be loosened and re-connected as often as desired. Thus, the re-use of the DILO seal is guaranteed. Due to the little depth of immersion of DILO groove and tongue the tubes can be immediately pulled out laterally after losing the clamping nut.

High pressure tube unions equipped with the DILO seal principle can be used in many field of application, particularly where systems need to be revised frequently or where critical operating conditions prevail.

DILO-Profile

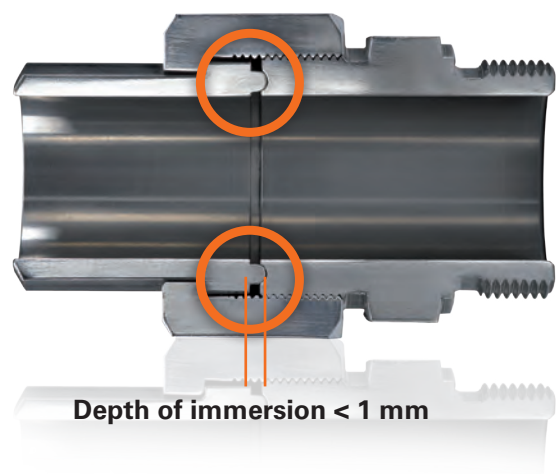
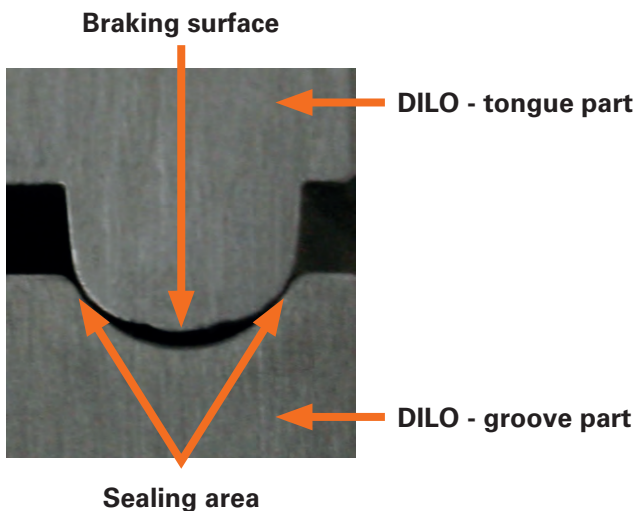

Product features

- Long term tightness with a leak rate of about <math>< 1 \text{ cm}^3</math> in 3 years
- Suitable for pressures up to 1,000 bar and vacuum
- Temperature resistant from -270 °C up to +500 °C (dependent on the material used)
- Applicable for all fluids with the correct steel grade
- Long term high level of gas tightness even when tube unions are frequently loosened and re-connected
- Short separation distance required to open a coupling which allows simple assembly and disassembly
- Resistant to vibrations without any additional protection
- Complete interchangeability of pieces of the same type

Material standards

Material number acc. to DIN	Material specification	AISI material specification	DILO material code letter
1.0460	P250GH	1022M	A
1.4571	X6CrNiMoTi17-12-2	316 Ti	C
1.7335	13CrMo4-5	A 182	D
1.4922	X20CrMoV11-1	---	Q

Surface treatment and cleaning

Before dispatching or storing the finished tube unions must be treated as follows:

a) ferritic material P250GH / 13CrMo4-5

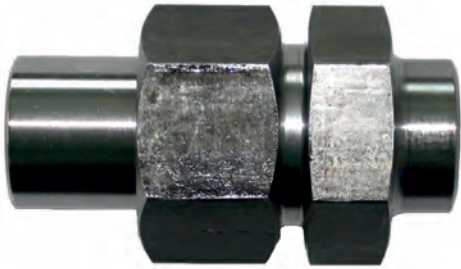

purified and lubricated

b) austenitic material / stainless steel

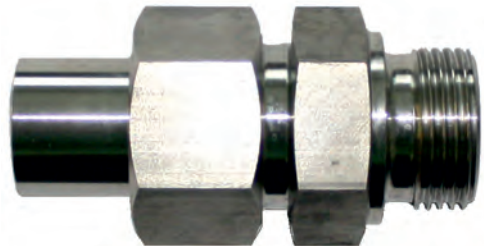

purified

Dimensions of tube connections / Standards

- All dimensions are indicated in mm
- Precision steel tubes (M Series) according to DIN EN 10305
- Steel tubes (J Series) according to DIN EN 10220

Marking / Identification

On the face of the clamping nut the following markings can be identified:

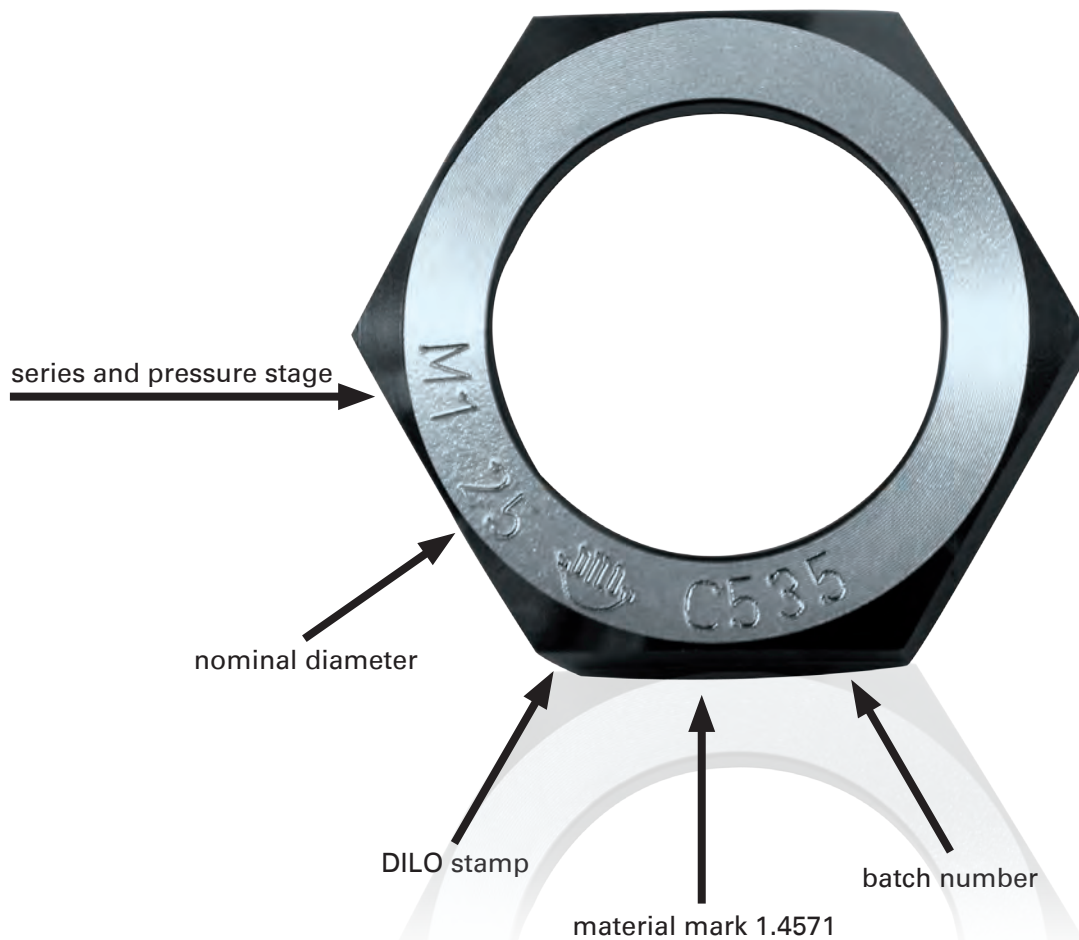

Blanking disks are not marked due to risk of damage.

Welding procedures

The following welding procedures can be used for processing DILO unions:

Welding phase according to DIN EN ISO 9692-1 no. 1.5 with 30°
 → Autogenous / WIG welding procedure

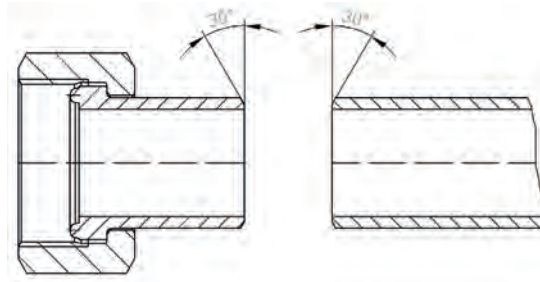

Adjustment of tube wall thickness

If the internal diameters between tube and weld-on stub differ from each other the welding part can be supplied with an adjusted tube wall thickness for aligned laying of tubes.

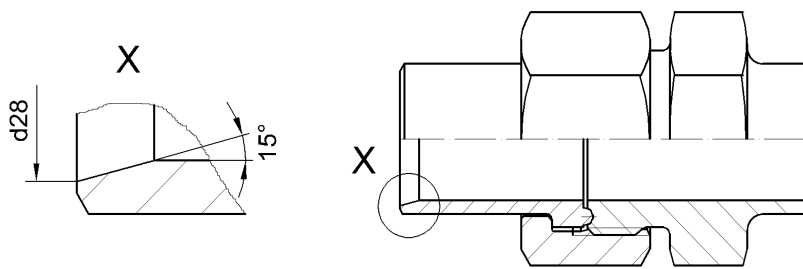

e. g. 21,3 x 2,0 tube connection dimension

Type: J1A16N1 = d28 = 17,3

Technical data of threads

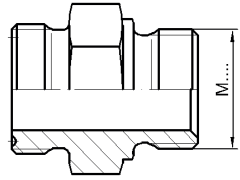
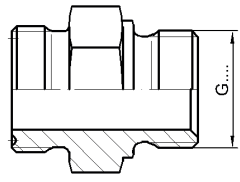
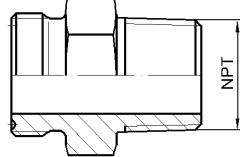
Type of thread	Standards	Code designation	Illustration
Metric thread	DIN 13 thread angle 60°	M	
Whitworth thread	DIN EN ISO 228-1 thread angle 55°	G	
American conical thread	ANSI/ASME B1.20.1 thread angle 60°	NPT	

Screw-in stub and screw-in holes

according to DIN 3852 - part 1:
with cylindric, metric thread
according to DIN 13

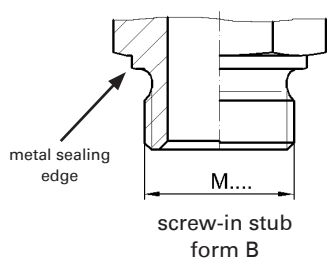

according to DIN EN ISO 1179:
with cylindric Whitworth thread
according to DIN EN ISO 228-1

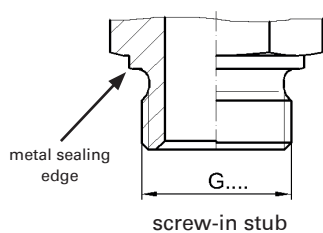

NPT:

Plug and screw-in hole with conical
NPT thread according to
ANSI / ASME B 1.20.1-1983

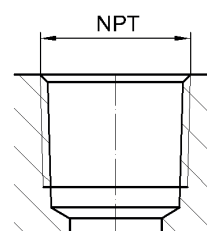
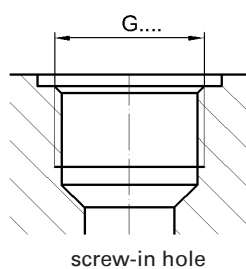
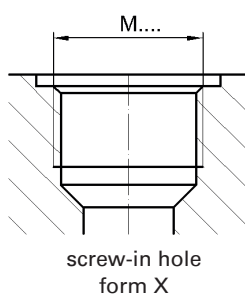
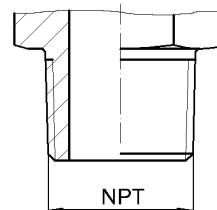

Mounting Instructions

General

DILO tube unions require no preliminary assembly or any special tools. Determine tube lengths exactly, cut off square, remove burrs and chamfer tube edges as per DIN EN ISO 9692-1. The only point requiring attention is to ensure that welded-in unions are in proper alignment.

- First tack-weld the DILO tube unions in the assembled form to the tubes (slightly tighten the clamping nut).
- Pay attention that when welding the negative pole is at that tube just being welded to the DILO tube union. In case of nonobservance of these two points there is the danger of a flashover between DILO groove and tongue part.
- After tack-welding uncouple and complete welding of tubes. Pay attention to the negative pole.
- Remake tube unions and correct any possible deviations from original alignment by heating the welds or the tubes.
- Residues of welding have to be removed by pickling.
- Any DILO hose connections with attached flexible tubing must be kept away from welding operations.
- Before final assembly check that DILO groove and tongue are clear of impurities and mechanical damage.
- In order to reduce friction, the tube unions should be oiled lightly with a suitable lubricant at threads and at locating surfaces of the clamping nut, specially concerning austenitic materials. Thus, the applied torque is being converted much better into axial force during mounting and also seizing of threads is avoided. When choosing lubricants, pay attention to operating temperatures, medium, corrosion and materials.
- When mounting DILO screw-in unions we recommend using softmetal-sealings (e. g. copper plates opposite the housing or block) for sealing of screw-in stub DIN 3852-1 form B and DIN EN ISO 1179-4.
- Tightening of the clamping nut according to torque table will achieve faultless sealing. (torque table see page 14)

Provided the above instructions are observed assembly is simple and time-saving. On the other hand too short or unaligned tubes lead to extra work.

When transporting the welded tubes to the place of assembly the sealing areas are to be protected by plastic caps in order to avoid mechanical damage.

Mounting Instructions

Mounting illustration:



1. Saw off the tubes rectangularly.

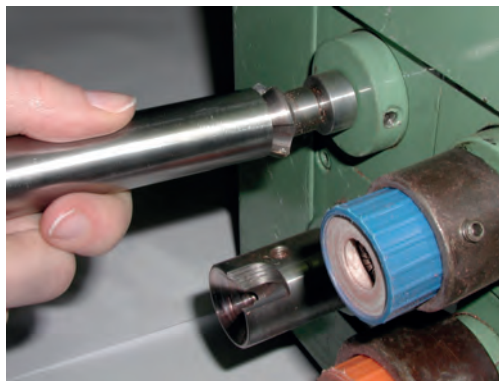

2. Deburring of the bores
Chamfer the tube edges according to DIN EN ISO 9692-1.



3. Tack-welding when bolted together.
Clamping nut slightly tightened.
Pay attention to the negative pole.



4. Unscrew the clamping nut and weld the tube connections.
Pay attention to the negative pole.



5. Right: aligned welded tube union



6. Wrong: not properly aligned welded tube union results in leakage

Mounting Instructions



7. Before assembling clean the DILO tongue and groove.



8. Lubricate - especially the austenitic steel - with suitable lubricants (e. g. type Never Seez from -180°C to $+1,400^{\circ}\text{C}$ / order no. 05-1172-R001)

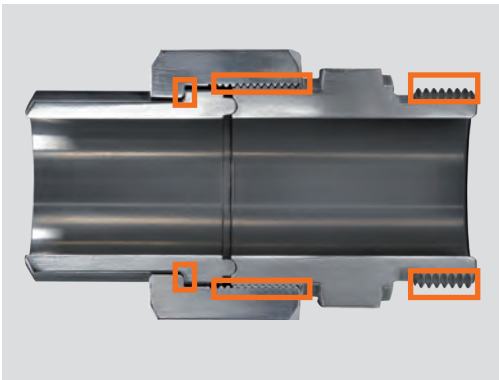

9. Observe the lubricating points of lubricant at a DILO tube union.



10. Tighten the clamping nut taking into consideration the specified torque by counteracting force.



11. Use soft metal seals according to DIN 7603 for sealing the screw-in stub opposite the housing or block.

Fittings for pressure ranges

up to **PN 640 and PN 1000 bar**

On request, the following fittings can be supplied

For the pressure range up to 640 bar = M6 Series

For the pressure range up to 1000 bar = M10 Series

Weld-on tube unions



Screw-in tube unions with metric or Whitworth thread



Angle weld-on unions



Tee weld-on unions



Gauge connection unions



Blanking disks



Torque table

Torque table for DILO tube unions

Nominal diameter	Series								Special version	
	M 1	MH 1	J 1	JH 1	M 2	J 2	M 3	J 3	M 6	M 10
	Operating overpressure								Operating overpressure	
	PN 100	PN 100	PN 100	PN 100	PN 200	PN 250	PN 320	PN 320	PN 640	PN 1000
3	20	25	20	25	20	20	20	20	25	30
4	20	30	25	30	25	25	25	25	35	50
5	-	-	-	-	-	-	25	25	-	-
6	25	40	25	40	30	30	30	30	50	70
8	25	45	30	45	35	35	40	40	65	80
10	30	55	35	50	45	45	50	60	90	110
12	35	65	45	55	55	50	60	75	110	125
16	40	80	55	80	65	75	80	90	145	205
20	50	100	70	110	80	110	100	120	220	245
25a	-	-	-	-	-	-	150	-	-	-
25	65	130	80	145	100	135	170	185	255	-
32	85	170	110	190	130	175	220	245	-	-
40a	110	-	-	-	-	-	-	-	-	-
40	145	220	190	250	170	240	-	290	-	-
50	220	-	290	-	220	300	-	-	-	-

Tightening torque in table is indicated in Nm.

Note:

The determined data are recommended values and may slightly differ.

During assembly, an aligned und unstressed tube connection as well as treatment of threads and bearing faces with lubricant is indispensable.

Torque table for DILO screw-in thread

Nominal diameter	Series								Special version	
	M 1	MH 1	J 1	JH 1	M 2	J 2	M 3	J 3	M 6	M 10
	Operating overpressure								Operating overpressure	
	PN 100	PN 100	PN 100	PN 100	PN 200	PN 250	PN 320	PN 320	PN 640	PN 1000
3	-	30	-	30	28/30	28/30	28/30	28/30	-	-
4	25	40	25	40	30	30	30	30	72	72
5	-	-	-	-	-	-	40	30	-	-
6	28/30	48/40	28/30	48/40	40	40	48/40	48/40	72	98/92
8	30	60/72	30	60/72	48/40	48/40	60/72	60/72	98	128
10	40	72	40	72	60/72	60/72	72	72	128	138
12	48/72	98/92	60/72	98/92	72	72	98/92	98/92	138	138
16	72	128	98/92	128	98/92	98/92	128	128	138	-
20	92	138	128	138	128	128	138	138	143	-
25a	-	-	-	-	-	-	143	-	-	-
25	128	143	138	143	138	138	143	143	152	-
32	138	152	143	152	143	143	152	152	-	-
40a	143	-	-	-	-	-	-	-	-	-
40	143	158	152	158	152	152	-	158	-	-
50	158	-	158	-	158	-	-	-	-	-

Tightening torque in table is indicated in Nm.

Note:

The determined data are recommended values and may slightly differ.

These values are valid for metric ISO DIN 13 threads and Whitworth ISO 228/1 threads.

In case two values are indicated in one column the first value applies to metric and the second to Whitworth thread.

During assembly, an aligned contact surface to the thread as well as treatment of threads with lubricant is indispensable.

Pressure stage table

Temperature-dependent pressure stage table of the DILO high pressure tube unions

Materials			
Material number acc. to DIN	Material specification	AISI material specification	DILO material-code letter
1.0460	P250GH	1022M	A
1.4571	X6CrNiMoTi17-12-2	316Ti	C
1.7335	13CrMo4-5	A 182	D
1.4922	X20CrMoV11-1	---	Q

series type	nominal pressure (bar)	DILO material code letter	all types	Nominal pressure up to temperature (°C)	Admissible operating pressure in bar at operating temperature (°C)									
					20	100	150	200	250	300	350	400	450	500
M 1	100	A	X	260	100	100	100	100	100	90	78	-	-	-
M 1	100	C	X	400	100	100	100	100	100	100	100	100	-	-
M 1	100	D	X	490	100	100	100	100	100	100	100	100	100	86
M 1	100	Q		20	100	93	90	86	82	78	74	71	62	52
MH 1	100	D	X	500	100	100	100	100	100	100	100	100	100	100
MH 1	100	Q		500	100	100	100	100	100	100	100	100	100	100
J 1	100	A	X	330	100	100	100	100	100	100	95	-	-	-
J 1	100	C	X	400	100	100	100	100	100	100	100	100	-	-
J 1	100	D	X	400	100	100	100	100	100	100	100	100	-	-
J 1	100	Q		20	100	93	90	86	82	78	74	71	62	52
JH 1	100	D	X	500	-	100	100	100	100	100	100	100	100	100
JH 1	100	Q		500	100	100	100	100	100	100	100	100	100	100
M 2	200	A	X	180	200	200	200	190	170	150	130	-	-	-
M 2	200	C	X	200	200	200	200	200	193	185	178	171	-	-
M 2	200	D	X	350	200	200	200	200	200	200	200	190	167	145
M 2	200	Q		20	200	188	180	173	165	158	151	144	124	105
J 2	250	A	X	140	250	250	235	220	195	170	150	-	-	-
J 2	250	C	X	140	250	250	246	226	215	207	198	190	-	-
J 2	250	D	X	300	250	250	250	250	250	250	230	220	192	165
J 2	250	Q		20	250	188	180	173	165	158	151	144	124	105
M 3	320	A	X	150	320	320	320	285	255	225	195	-	-	-
M 3	320	C	X	145	320	320	317	295	284	274	262	252	-	-
M 3	320	D	X	300	320	320	320	320	320	320	295	280	248	215
M 3	320	Q		220	320	320	320	320	310	295	281	268	230	195
J 3	320	A	X	165	320	320	320	295	262	230	200	-	-	-
J 3	320	C	X	170	320	320	320	302	292	282	271	261	-	-
J 3	320	D	X	20	320	320	320	320	320	320	305	290	255	220
J 3	320	Q		220	-	-	-	320	310	295	281	268	230	195

M 6	640	A	X	150	640	640	640	570	507	445	385	-	-	-
M 6	640	C	X	140	640	640	632	590	565	540	520	500	-	-
M 6	640	D	X	300	640	640	640	640	640	640	590	560	492	425
M 6	640	Q		415	640	640	640	640	640	640	640	640	545	450
M 10	1000	A	X	80	1000	990	890	790	705	620	540	-	-	-
M 10	1000	C	X	55	1000	940	880	820	780	742	721	700	-	-
M 10	1000	D	X	200	1000	1000	1000	1000	945	890	820	780	748	715
M 10	1000	Q		460	1000	1000	1000	1000	1000	1000	1000	1000	1000	875

Quality assurance

Quality assurance takes highest priority within the DILO organization. Our approved and authorized experts permanently check the material carefully. The entire raw material is ordered according to DILO approval / order regulations. Thus, it is guaranteed that all necessary tests have been executed which is confirmed in test certificates according to EN 10204 (3.1).

By marking the raw material and end products, the identity and traceability of materials is guaranteed.

Our fittings are TÜV-approved. Furthermore, our company is certified according to ISO 9001:2008.

Approvals and certifications provided by DILO:

DILO products have been approved by international classification organisations such as:

- Certification according to ISO 9001: 2008
- Confirmation quality assurance according to KTA 1401
- HPO approval as pressure equipment manufacturer
- Production control in accordance with 2014/68/EU regulations



Straight unions



Straight DILO tube unions are available with weld-on ends for applications where high vibration resistance is required. They are also available with weld-on end and screw-in thread. Different threads enable appropriate connections.

On request, we also supply unions in materials with standing temperatures from -270 °C up to +500 °C. Permanent tightness is guaranteed, no matter which version is selected!

■ Straight unions

- Weld-on tube unions 18
- Screw-in tube unions with metric thread 21
- Screw-in tube unions with Whitworth thread 24
- Screw-in tube unions with NPT thread 27

Weld-on tube unions

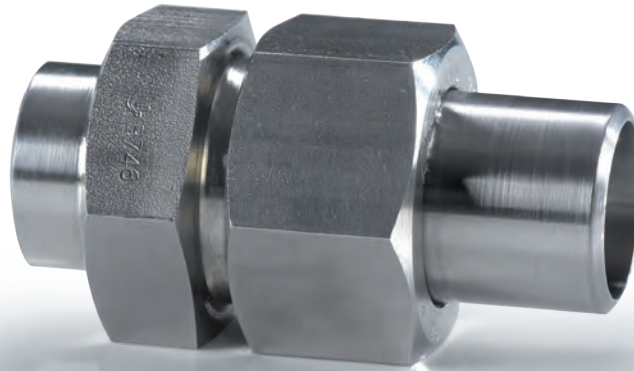

- With weld-on ends
- Available for tube diameters from DN 3 up to DN 50
- Temperature-resistant from -270 °C up to +500 °C (dependant on the material used)
- Available for pressures up to 1.000 bar on request
- Available in DIN EN materials: 1.0460 and 1.4571
Other materials on request.
- Three-part union consisting of weld-on stub, clamping nut and weld-on screw stub

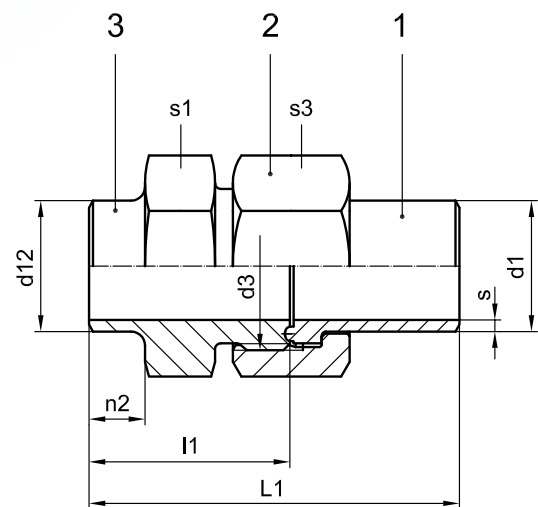

M1A Series for pressures up to PN 100:

DN	d ₁	s	d ₃	d ₁₂	L ₁	l ₁	n ₂	s ₁	s ₃	Order number	Material number	
											1.0460	1.4571
4	6	1,25	M 14x1,5	6	46	25	9	14	17	M1A 4		
6	8	1,5	M 16x1,5	8	49	26	10	17	19	M1A 6		
8	10	1,5	M 18x1,5	10	54	29	10	19	22	M1A 8		
10	12	1,75	M 20x1,5	12	57	30	10	22	24	M1A 10		
12	15	2	M 22x1,5	15	60	31	10	24	27	M1A 12		
16	18	2	M 26x1,5	18	63	32	10	27	32	M1A 16		
20	22	2	M 30x1,5	22	72	38	12	32	36	M1A 20		
25	28	2,5	M 36x2	28	80	43	12	41	41	M1A 25		
32	35	2,5	M 45x2	35	86	46	14	46	50	M1A 32		
40a	42	3	M 52x2	42	95	52	16	55	60	M1A 40a		
40	44	3	M 56x2	44	96	53	16	60	65	M1A 40		
50	57	4	M 68x2	57	106	58	18	70	75	M1A 50		

 Parts available from stock

J1A Series for pressures up to PN 100:

DN	d ₁	s	d ₃	d ₁₂	L ₁	l ₁	n ₂	s ₁	s ₃	Order number	Material number	
											1.0460	1.4571
4	6	1,25	M 14x1,5	6	46	25	9	14	17	J1A 4		
6	8	1,5	M 16x1,5	8	49	26	10	17	19	J1A 6		
8	10	1,5	M 18x1,5	10	54	29	10	19	22	J1A 8		
10	13,5	1,75	M 22x1,5	13,5	64	33	10	24	27	J1A 10		
12	17	2,5	M 24x1,5	17	65	34	10	27	30	J1A 12		
16	21	2,5	M 30x2	21	76	40	12	32	36	J1A 16		
20	27	3	M 36x2	27	81	44	12	41	41	J1A 20		
25	34	3,5	M 45x2	34	87	47	14	46	50	J1A 25		
32	42	3,5	M 52x2	42	98	54	16	55	60	J1A 32		
40	49	4	M 60x2	49	106	58	17	65	70	J1A 40		
50	60	5	M 72x2	60	114	63	20	75	80	J1A 50		

M2A Series for pressures up to PN 200:

DN	d ₁	s	d ₃	d ₁₂	L ₁	l ₁	n ₂	s ₁	s ₃	Order number	Material number	
											1.0460	1.4571
3	6	1,5	M 14x1,5	6	52	27	9	17	19	M2A 3		
4	8	2	M 16x1,5	8	53	28	10	17	22	M2A 4		
6	10	2	M 18x1,5	10	54	29	10	19	22	M2A 6		
8	12	2	M 20x1,5	12	57	30	10	22	24	M2A 8		
10	13,5	1,75	M 22x1,5	13,5	64	33	10	24	27	M2A 10		
12	16	2,5	M 24x1,5	16	65	34	10	27	30	M2A 12		
16	20	2,5	M 30x2	20	76	40	12	32	36	M2A 16		
20	25	2,5	M 36x2	25	86	45	12	41	46	M2A 20		
25	30	3	M 42x2	30	94	50	14	46	50	M2A 25		
32	38	3,5	M 52x2	38	106	56	16	55	60	M2A 32		
40	44	4,25	M 56x2	44	116	61	18	60	65	M2A 40		
50	57	6	M 68x2	57	126	66	20	70	80	M2A 50		

J2A Series for pressures up to PN 250:

DN	d ₁	s	d ₃	d ₁₂	L ₁	l ₁	n ₂	s ₁	s ₃	Order number	Material number	
											1.0460	1.4571
3	6	1,5	M 14x1,5	6	52	27	9	17	19	J2A 3		
4	8	2	M 16x1,5	8	53	28	10	17	22	J2A 4		
6	10	2	M 18x1,5	10	54	29	10	19	22	J2A 6		
8	12	2	M 20x1,5	12	57	30	10	22	24	J2A 8		
10	13,5	1,75	M 22x1,5	13,5	64	33	10	24	27	J2A 10		
12	17	2,5	M 24x1,5	17	65	34	10	27	30	J2A 12		
16	21	2,5	M 30x2	21	76	40	12	32	36	J2A 16		
20	27	3,5	M 36x2	27	86	45	12	41	46	J2A 20		
25	34	4,5	M 45x2	34	94	50	14	46	55	J2A 25		
32	42	4	M 52x2	42	106	56	16	55	60	J2A 32		
40	50	5,5	M 64x2	50	118	63	18	65	75	J2A 40		

 Parts available from stock

Weld-on tube unions

M3A Series for pressures up to PN 320:

DN	d ₁	s	d ₃	d ₁₂	L ₁	l ₁	n ₂	s ₁	s ₃	Order number	Material number	
											1.0460	1.4571
3	6	1,5	M 14x1,5	6	52	27	9	17	19	M3A 3		
4	8	2	M 16x1,5	8	53	28	10	17	22	M3A 4		
5	10	2,5	M 18x1,5	10	54	29	10	19	24	M3A 5		
6	12	3	M 20x1,5	12	61	32	10	22	27	M3A 6		
8	13,5	2,75	M 22x1,5	13,5	64	33	10	24	30	M3A 8		
10	16	3	M 24x1,5	16	73	38	12	27	32	M3A 10		
12	20	4	M 30x2	20	84	44	14	32	36	M3A 12		
16	25	4,5	M 36x2	25	92	49	14	41	46	M3A 16		
20	30	5	M 42x2	30	102	54	16	46	50	M3A 20		
25a	35	5,5	M 48x2	35	109	58	17	50	55	M3A 25a		
25	38	6	M 52x2	38	114	60	18	55	60	M3A 25		
32	44	6,75	M 60x2	44	127	66	20	65	70	M3A 32		

J3A Series for pressures up to PN 320:

DN	d ₁	s	d ₃	d ₁₂	L ₁	l ₁	n ₂	s ₁	s ₃	Order number	Material number	
											1.0460	1.4571
3	6	1,5	M 14x1,5	6	52	27	9	17	19	J3A 3		
4	8	2	M 16x1,5	8	53	28	10	17	22	J3A 4		
5	10	2,5	M 18x1,5	10	54	29	10	19	24	J3A 5		
6	12	3	M 20x1,5	12	61	32	10	22	27	J3A 6		
8	13,5	2,75	M 22x1,5	13,5	64	33	10	24	30	J3A 8		
10	17	3	M 27x2	17	76	41	12	30	36	J3A 10		
12	21	4	M 33x2	21	86	46	14	36	41	J3A 12		
16	27	4,5	M 39x2	27	94	51	14	41	46	J3A 16		
20	34	5,5	M 48x2	34	107	58	17	50	55	J3A 20		
25	42	7	M 56x2	42	116	62	18	60	65	J3A 25		
32	48	6,5	M 64x2	48	128	67	20	65	70	J3A 32		

For orders on individual parts we need the following information:

Pieces	Component	Designation	Order number	Material number
1	1	Weld-on stub	(Series)-(DN)- 1	_____
1	2	Clamping nut	(Series)-(DN)- 2	_____
1	3	Weld-on screw stub	(Series)-(DN)- 3	_____

Materials: see „Material standards“ page 6

Screw-in tube unions

with metric thread



- With weld-on end and screw-in thread
- Available for tube diameters from DN 3 up to DN 50
- Temperature-resistant from -270 °C up to +500 °C (dependant on the material used)
- Available in DIN EN materials: 1.0460 and 1.4571
Other materials on request.
- Three-part union consisting of weld-on stub, clamping nut and screw-in stub

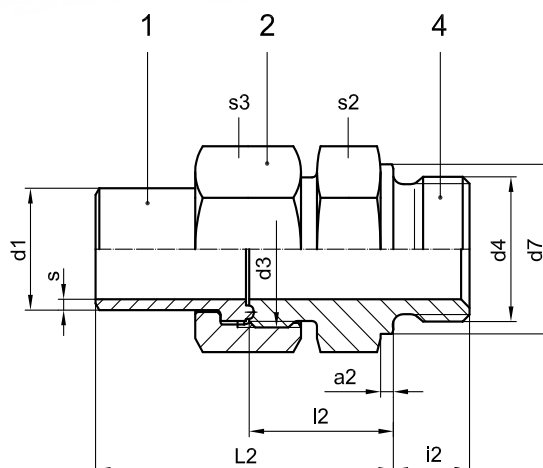

M1B Series for pressures up to PN 100:

DN	d_1	s	d_3	d_4	d_7	L_2	l_2	i_2	a_2	s_2	s_3	Order number	Material number	
													1.0460	1.4571
4	6	1,25	M 14x1,5	M 10x1	14	39	18	8	1,5	14	17	M1B 4		
6	8	1,5	M 16x1,5	M 12x1,5	17	41	18	12	2	17	19	M1B 6		
8	10	1,5	M 18x1,5	M 14x1,5	19	46	21	12	2	19	22	M1B 8		
10	12	1,75	M 20x1,5	M 16x1,5	21	49	22	12	2	22	24	M1B 10		
12	15	2	M 22x1,5	M 18x1,5	23	54	24	12	2,5	24	27	M1B 12		
16	18	2	M 26x1,5	M 22x1,5	27	56	25	14	3	27	32	M1B 16		
20	22	2	M 30x1,5	M 26x1,5	31	63	29	16	3	32	36	M1B 20		
25	28	2,5	M 36x2	M 33x2	39	71	34	18	3	41	41	M1B 25		
32	35	2,5	M 45x2	M 42x2	49	76	36	20	3	50	50	M1B 32		
40a	42	3	M 52x2	M 48x2	55	82	39	22	3	55	60	M1B 40a		
40	44	3	M 56x2	M 48x2	55	83	40	22	3	60	65	M1B 40		
50	57	4	M 68x2	M 60x2	68	92	44	24	3,5	70	75	M1B 50		

Screw-in tube unions

with metric thread

J1B Series for pressures up to PN 100:

DN	d ₁	s	d ₃	d ₄	d ₇	L ₂	l ₂	i ₂	a ₂	s ₂	s ₃	Order number	Material number	
													1.0460	1.4571
4	6	1,25	M 14x1,5	M 10x1	14	39	18	8	1,5	14	17	J1B 4		
6	8	1,5	M 16x1,5	M 12x1,5	17	41	18	12	2	17	19	J1B 6		
8	10	1,5	M 18x1,5	M 14x1,5	19	46	21	12	2	19	22	J1B 8		
10	13,5	1,75	M 22x1,5	M 16x1,5	21	57	25	12	2	24	27	J1B 10		
12	17	2,5	M 24x1,5	M 20x1,5	25	58	27	14	2,5	27	30	J1B 12		
16	21	2,5	M 30x2	M 27x2	32	67	31	16	3	32	36	J1B 16		
20	27	3	M 36x2	M 33x2	39	73	36	18	3	41	41	J1B 20		
25	34	3,5	M 45x2	M 42x2	49	76	36	20	3	50	50	J1B 25		
32	42	3,5	M 52x2	M 48x2	55	84	40	22	3	55	60	J1B 32		
40	49	4	M 60x2	M 56x2	64	92	44	24	3,5	65	70	J1B 40		
50	60	5	M 72x2	M 60x2	68	97	46	24	3,5	75	80	J1B 50		

M2B Series for pressures up to PN 200:

DN	d ₁	s	d ₃	d ₄	d ₇	L ₂	l ₂	i ₂	a ₂	s ₂	s ₃	Order number	Material number	
													1.0460	1.4571
3	6	1,5	M 14x1,5	M 12x1,5	17	45	20	12	2	17	19	M2B 3		
4	8	2	M 16x1,5	M 14x1,5	19	46	21	12	2	19	22	M2B 4		
6	10	2	M 18x1,5	M 16x1,5	21	47	22	12	2	22	22	M2B 6		
8	12	2	M 20x1,5	M 18x1,5	23	51	24	12	2,5	24	24	M2B 8		
10	13,5	1,75	M 22x1,5	M 20x1,5	25	58	27	14	2,5	27	27	M2B 10		
12	16	2,5	M 24x1,5	M 22x1,5	27	58	27	14	3	27	30	M2B 12		
16	20	2,5	M 30x2	M 27x2	32	67	31	16	3	32	36	M2B 16		
20	25	2,5	M 36x2	M 33x2	39	77	36	18	3	41	46	M2B 20		
25	30	3	M 42x2	M 42x2	49	84	40	20	3	50	50	M2B 25		
32	38	3,5	M 52x2	M 48x2	55	93	43	22	3	55	60	M2B 32		
40	44	4,25	M 56x2	M 56x2	64	102	47	24	3,5	65	65	M2B 40		
50	57	6	M 68x2	M 60x2	68	109	49	24	3,5	70	80	M2B 50		

J2B Series for pressures up to PN 250:

DN	d ₁	s	d ₃	d ₄	d ₇	L ₂	l ₂	i ₂	a ₂	s ₂	s ₃	Order number	Material number	
													1.0460	1.4571
3	6	1,5	M 14x1,5	M 12x1,5	17	46	20	12	2	17	19	J2B 3		
4	8	2	M 16x1,5	M 14x1,5	19	46	21	12	2	19	22	J2B 4		
6	10	2	M 18x1,5	M 16x1,5	21	48	22	12	2	22	22	J2B 6		
8	12	2	M 20x1,5	M 18x1,5	23	50	24	12	2,5	24	24	J2B 8		
10	13,5	1,75	M 22x1,5	M 20x1,5	25	58	27	14	2,5	27	27	J2B 10		
12	17	2,5	M 24x1,5	M 22x1,5	27	59	28	14	3	27	30	J2B 12		
16	21	2,5	M 30x2	M 27x2	32	68	32	16	3	32	36	J2B 16		
20	27	3,5	M 36x2	M 33x2	39	77	36	18	3	41	46	J2B 20		
25	34	4,5	M 45x2	M 42x2	49	85	41	20	3	50	55	J2B 25		
32	42	4	M 52x2	M 48x2	55	94	44	22	3	55	60	J2B 32		
40	50	5,5	M 64x2	M 56x2	64	102	47	24	3,5	65	75	J2B 40		

M3B Series for pressures up to PN 320:

DN	d ₁	s	d ₃	d ₄	d ₇	L ₂	l ₂	i ₂	a ₂	s ₂	s ₃	Order number	Material number	
													1.0460	1.4571
3	6	1,5	M 14x1,5	M 12x1,5	17	46	20	12	2	17	19	M3B 3		
4	8	2	M 16x1,5	M 14x1,5	19	46	21	12	2	19	22	M3B 4		
5	10	2,5	M 18x1,5	M 16x1,5	21	48	22	12	2	22	24	M3B 5		
6	12	3	M 20x1,5	M 18x1,5	23	54	26	12	2,5	24	27	M3B 6		
8	13,5	2,75	M 22x1,5	M 20x1,5	25	58	27	14	2,5	27	30	M3B 8		
10	16	3	M 24x1,5	M 22x1,5	27	64	29	14	3	27	32	M3B 10		
12	20	4	M 30x2	M 27x2	32	73	33	16	3	32	36	M3B 12		
16	25	4,5	M 36x2	M 33x2	39	81	38	18	3	41	46	M3B 16		
20	30	5	M 42x2	M 42x2	49	90	42	20	3	50	50	M3B 20		
25a	35	5,5	M 48x2	M 48x2	55	96	45	22	3	55	55	M3B 25a		
25	38	6	M 52x2	M 48x2	55	99	45	22	3	55	60	M3B 25		
32	44	6,75	M 60x2	M 56x2	64	110	49	24	3,5	65	70	M3B 32		

J3B Series for pressures up to PN 320:

DN	d ₁	s	d ₃	d ₄	d ₇	L ₂	l ₂	i ₂	a ₂	s ₂	s ₃	Order number	Material number	
													1.0460	1.4571
3	6	1,5	M 14x1,5	M 12x1,5	17	46	20	12	2	17	19	J3B 3		
4	8	2	M 16x1,5	M 14x1,5	19	46	21	12	2	19	22	J3B 4		
5	10	2,5	M 18x1,5	M 16x1,5	21	48	22	12	2	22	24	J3B 5		
6	12	3	M 20x1,5	M 18x1,5	23	54	26	12	2,5	24	27	J3B 6		
8	13,5	2,75	M 22x1,5	M 20x1,5	25	58	27	14	2,5	27	30	J3B 8		
10	17	3	M 27x2	M 22x1,5	27	67	32	14	3	30	36	J3B 10		
12	21	4	M 33x2	M 27x2	32	75	35	16	3	36	41	J3B 12		
16	27	4,5	M 39x2	M 33x2	39	82	39	18	3	41	46	J3B 16		
20	34	5,5	M 48x2	M 42x2	49	94	45	20	3	50	55	J3B 20		
25	42	7	M 56x2	M 48x2	55	101	47	22	3	60	65	J3B 25		
32	48	6,5	M 64x2	M 56x2	64	111	50	24	3,5	65	70	J3B 32		

For orders on individual parts we need the following information:

Pieces	Component	Designation	Order number	Material number
1	1	Weld-on stub	(Series)-(DN)- 1	_____
1	2	Clamping nut	(Series)-(DN)- 2	_____
1	4	Screw-in stub	(Series)-(DN)- 4	_____

Materials: see „Material standards“ page 6

Screw-in tube unions

with Whitworth thread



- With weld-on end and screw-in thread
- Available for tube diameters from DN 3 up to DN 50
- Temperature-resistant from -270 °C up to +500 °C (dependant on the material used)
- Available for pressures up to 1.000 bar on request
- Available in DIN EN materials: 1.0460 and 1.4571
Other materials on request.
- Three-part union consisting of weld-on stub, clamping nut and screw-in stub

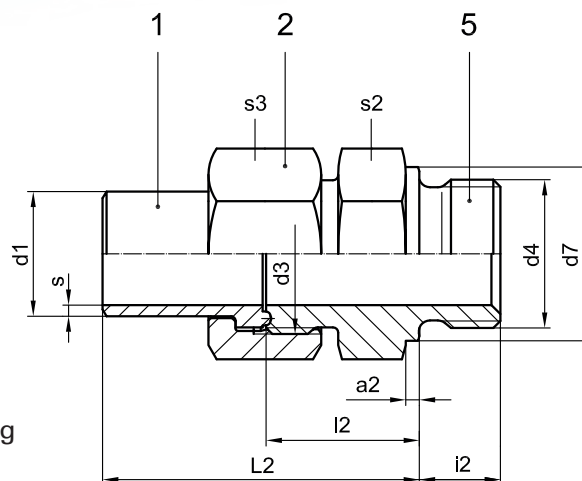

M1B-G Series for pressures up to PN 100:

DN	d ₁	s	d ₃	d ₄	d ₇	L ₂	l ₂	i ₂	a ₂	s ₂	s ₃	Order number	Material number	
													1.0460	1.4571
4	6	1,25	M 14x1,5	G 1/8 A	14	39	18	8	1,5	14	17	M1B 4 G		
6	8	1,5	M 16x1,5	G ¼ A	18	41	18	12	2	19	19	M1B 6 G		
8	10	1,5	M 18x1,5	G ¼ A	18	46	21	12	2	19	22	M1B 8 G		
10	12	1,75	M 20x1,5	G 3/8 A	22	49	22	12	2,5	22	24	M1B 10 G		
12	15	2	M 22x1,5	G ½ A	26	54	25	14	3	27	27	M1B 12 G		
16	18	2	M 26x1,5	G ½ A	26	56	25	14	3	27	32	M1B 16 G		
20	22	2	M 30x1,5	G ¾ A	32	63	29	16	3	32	36	M1B 20 G		
25	28	2,5	M 36x2	G 1 A	39	71	34	18	3	41	41	M1B 25 G		
32	35	2,5	M 45x2	G 1 ¼ A	49	76	36	20	3	50	50	M1B 32 G		
40a	42	3	M 52x2	G 1 ½ A	55	82	39	22	3	55	60	M1B 40a G		
40	44	3	M 56x2	G 1 ½ A	55	83	40	22	3	60	65	M1B 40 G		
50	57	4	M 68x2	G 2 A	68	92	44	24	3,5	70	75	M1B 50 G		

Parts available from stock

J1B-G Series for pressures up to PN 100:

DN	d ₁	s	d ₃	d ₄	d ₇	L ₂	l ₂	i ₂	a ₂	s ₂	s ₃	Bestellzei- chen	Material number	
													1.0460	1.4571
4	6	1,25	M 14x1,5	G 1/8 A	14	39	18	8	1,5	14	17	J1B 4 G		
6	8	1,5	M 16x1,5	G ¼ A	18	41	18	12	2	19	19	J1B 6 G		
8	10	1,5	M 18x1,5	G ¼ A	18	46	21	12	2	19	22	J1B 8 G		
10	13,5	1,75	M 22x1,5	G 3/8 A	22	57	26	12	2,5	24	27	J1B 10 G		
12	17	2,5	M 24x1,5	G ½ A	26	58	27	14	3	27	30	J1B 12 G		
16	21	2,5	M 30x2	G ¾ A	32	67	31	16	3	32	36	J1B 16 G		
20	27	3	M 36x2	G 1 A	39	73	36	18	3	41	41	J1B 20 G		
25	34	3,5	M 45x2	G 1 ¼ A	49	76	36	20	3	50	50	J1B 25 G		
32	42	3,5	M 52x2	G 1 ½ A	55	84	40	22	3	55	60	J1B 32 G		
40	49	4	M 60x2	G 1 ¾ A	62	92	44	24	3,5	65	70	J1B 40 G		
50	60	5	M 72x2	G 2 A	68	97	46	24	3,5	75	80	J1B 50 G		

M2B-G Series for pressures up to PN 200:

DN	d ₁	s	d ₃	d ₄	d ₇	L ₂	l ₂	i ₂	a ₂	s ₂	s ₃	Bestellzei- chen	Material number	
													1.0460	1.4571
3	6	1,5	M 14x1,5	G ¼ A	18	46	21	12	2	19	19	M2B 3 G		
4	8	2	M 16x1,5	G ¼ A	18	46	21	12	2	19	22	M2B 4 G		
6	10	2	M 18x1,5	G 3/8 A	22	48	23	12	2,5	22	22	M2B 6 G		
8	12	2	M 20x1,5	G 3/8 A	22	50	23	12	2,5	22	24	M2B 8 G		
10	13,5	1,75	M 22x1,5	G ½ A	26	58	27	14	3	27	27	M2B 10 G		
12	16	2,5	M 24x1,5	G ½ A	26	58	27	14	3	27	30	M2B 12 G		
16	20	2,5	M 30x2	G ¾ A	32	67	31	16	3	32	36	M2B 16 G		
20	25	2,5	M 36x2	G 1 A	39	77	36	18	3	41	46	M2B 20 G		
25	30	3	M 42x2	G 1 ¼ A	49	84	40	20	3	50	50	M2B 25 G		
32	38	3,5	M 52x2	G 1 ½ A	55	93	43	22	3	55	60	M2B 32 G		
40	44	4,25	M 56x2	G 1 ¾ A	62	102	47	24	3,5	65	65	M2B 40 G		
50	57	6	M 68x2	G 2 A	68	109	49	24	3,5	70	80	M2B 50 G		

J2B-G Series for pressures up to PN 250:

DN	d ₁	s	d ₃	d ₄	d ₇	L ₂	l ₂	i ₂	a ₂	s ₂	s ₃	Bestellzei- chen	Material number	
													1.0460	1.4571
3	6	1,5	M 14x1,5	G ¼ A	18	46	21	12	2	19	19	J2B 3 G		
4	8	2	M 16x1,5	G ¼ A	18	46	21	12	2	19	22	J2B 4 G		
6	10	2	M 18x1,5	G 3/8 A	22	48	23	12	2,5	22	22	J2B 6 G		
8	12	2	M 20x1,5	G 3/8 A	22	50	23	12	2,5	22	24	J2B 8 G		
10	13,5	1,75	M 22x1,5	G ½ A	26	58	27	14	3	27	27	J2B 10 G		
12	17	2,5	M 24x1,5	G ½ A	26	59	28	14	3	27	30	J2B 12 G		
16	21	2,5	M 30x2	G ¾ A	32	68	32	16	3	32	36	J2B 16 G		
20	27	3,5	M 36x2	G 1 A	39	77	36	18	3	41	46	J2B 20 G		
25	34	4,5	M 45x2	G 1 ¼ A	49	85	41	20	3	50	55	J2B 25 G		
32	42	4	M 52x2	G 1 ½ A	55	94	44	22	3	55	60	J2B 32 G		
40	50	5,5	M 64x2	G 1 ¾ A	62	102	47	24	3,5	65	75	J2B 40 G		

 Parts available from stock

Screw-in tube unions

with Whitworth thread

M3B-G Series for pressures up to PN 320:

DN	d ₁	s	d ₃	d ₄	d ₇	L ₂	l ₂	i ₂	a ₂	s ₂	s ₃	Order number	Material number	
													1.0460	1.4571
3	6	1,5	M 14x1,5	G ¼ A	18	46	21	12	2	19	19	M3B 3 G		
4	8	2	M 16x1,5	G ¼ A	18	46	21	12	2	19	22	M3B 4 G		
5	10	2,5	M 18x1,5	G 3/8A	22	48	23	12	2,5	22	24	M3B 5 G		
6	12	3	M 20x1,5	G 3/8 A	22	54	25	12	2,5	22	27	M3B 6 G		
8	13,5	2,75	M 22x1,5	G ½ A	26	58	27	14	3	27	30	M3B 8 G		
10	16	3	M 24x1,5	G ½ A	26	64	29	14	3	27	32	M3B 10 G		
12	20	4	M 30x2	G ¾ A	32	73	33	16	3	32	36	M3B 12 G		
16	25	4,5	M 36x2	G 1 A	39	81	38	18	3	41	46	M3B 16 G		
20	30	5	M 42x2	G 1 ¼ A	49	90	42	20	3	50	50	M3B 20 G		
25a	35	5,5	M 48x2	G 1 ½ A	55	96	45	22	3	55	55	M3B 25a G		
25	38	6	M 52x2	G 1 ½ A	55	99	45	22	3	55	60	M3B 25 G		
32	44	6,75	M 60x2	G 1 ¾ A	62	110	49	24	3,5	65	70	M3B 32 G		

J3B-G Series for pressures up to PN 320:

DN	d ₁	s	d ₃	d ₄	d ₇	L ₂	l ₂	i ₂	a ₂	s ₂	s ₃	Order number	Material number	
													1.0460	1.4571
3	6	1,5	M 14x1,5	G ¼ A	18	46	21	12	2	19	19	J3B 3 G		
4	8	2	M 16x1,5	G ¼ A	18	46	21	12	2	19	22	J3B 4 G		
5	10	2,5	M 18x1,5	G 3/8A	22	48	23	12	2,5	22	24	J3B 5 G		
6	12	3	M 20x1,5	G 3/8 A	22	54	25	12	2,5	22	27	J3B 6 G		
8	13,5	2,75	M 22x1,5	G ½ A	26	58	27	14	3	27	30	J3B 8 G		
10	17	3	M 27x2	G ½ A	26	67	32	14	3	30	36	J3B 10 G		
12	21	4	M 33x2	G ¾ A	32	75	35	16	3	36	41	J3B 12 G		
16	27	4,5	M 39x2	G 1 A	39	82	39	18	3	41	46	J3B 16 G		
20	34	5,5	M 48x2	G 1 ¼ A	49	94	45	20	3	50	55	J3B 20 G		
25	42	7	M 56x2	G 1 ½ A	55	101	47	22	3	60	65	J3B 25 G		
32	48	6,5	M 64x2	G 1 ¾ A	62	111	50	24	3,5	65	70	J3B 32 G		

For orders on individual parts we need the following information:

Pieces	Component	Designation	Order number	Material number
1	1	Weld-on stub	(Series)-(DN)- 1	_____
1	2	Clamping nut	(Series)-(DN)- 2	_____
1	5	Screw-in stub	(Series)-(DN)- 5	_____

Materials: see „Material standards“ page 6

Accessories: copper seals
see page 66



Screw-in tube unions

with NPT thread

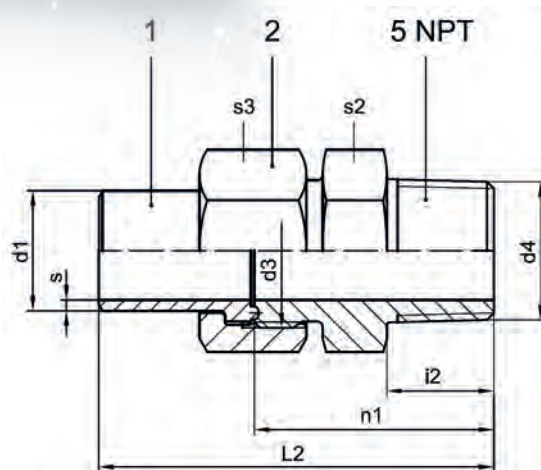

- With weld-on end and screw-in thread
- Available for tube diameters from DN 3 up to DN 50
- Temperature-resistant from -270 °C up to +500 °C (dependant on the material used)
- Available in DIN EN materials: 1.0460 and 1.4571
Other materials on request.
- Three-part union consisting of weld-on stub, clamping nut and screw-in stub

M1B-NPT Series for pressures up to PN 100:

DN	d ₁	s	d ₃	d ₄	L ₂	n ₁	i ₂	s ₂	s ₃	Bestellzeichen	Material number	
											1.0460	1.4571
4	6	1,25	M 14x1,5	1/8 NPT	47	26	10	14	17	M1B 4 NPT		
6	8	1,5	M 16x1,5	1/4 NPT	55	32	15	19	19	M1B 6 NPT		
8	10	1,5	M 18x1,5	1/4 NPT	59	34	15	19	22	M1B 8 NPT		
10	12	1,75	M 20x1,5	3/8 NPT	62	35	15	22	24	M1B 10 NPT		
12	15	2	M 22x1,5	1/2 NPT	71	42	20	27	27	M1B 12 NPT		
16	18	2	M 26x1,5	1/2 NPT	73	42	20	27	32	M1B 16 NPT		
20	22	2	M 30x1,5	3/4 NPT	80	46	20	32	36	M1B 20 NPT		
25	28	2,5	M 36x2	1 NPT	93	56	25	41	41	M1B 25 NPT		
32	35	2,5	M 45x2	1 1/4 NPT	98	58	25,5	50	50	M1B 32 NPT		
40a	42	3	M 52x2	1 1/2 NPT	105	62	26	55	60	M1B 40a NPT		
40	44	3	M 56x2	1 1/2 NPT	106	63	26	60	65	M1B 40 NPT		
50	57	4	M 68x2	2 NPT	115	67	27	70	75	M1B 50 NPT		

 Parts available from stock

Screw-in tube unions

with NPT thread

J1B-NPT Series for pressures up to PN 100:

DN	d ₁	s	d ₃	d ₄	L ₂	n ₁	i ₂	s ₂	s ₃	Order number	Material number	
											1.0460	1.4571
4	6	1,25	M 14x1,5	1/8 NPT	47	26	10	14	17	J1B 4 NPT		
6	8	1,5	M 16x1,5	¼ NPT	55	32	15	19	19	J1B 6 NPT		
8	10	1,5	M 18x1,5	¼ NPT	59	34	15	19	22	J1B 8 NPT		
10	13,5	1,75	M 22x1,5	3/8 NPT	71	40	15	24	27	J1B 10 NPT		
12	17	2,5	M 24x1,5	½ NPT	77	46	20	27	30	J1B 12 NPT		
16	21	2,5	M 30x2	¾ NPT	86	50	20	32	36	J1B 16 NPT		
20	27	3	M 36x2	1 NPT	94	57	25	41	41	J1B 20 NPT		
25	34	3,5	M 45x2	1 ¼ NPT	102	62	25,5	46	50	J1B 25 NPT		
32	42	3,5	M 52x2	1 ½ NPT	109	65	26	55	60	J1B 32 NPT		
40	49	4	M 60x2	2 NPT	119	71	27	65	70	J1B 40 NPT		
50	60	5	M 72x2	2 NPT	124	73	27	75	80	J1B 50 NPT		

M2B-NPT Series for pressures up to PN 200:

DN	d ₁	s	d ₃	d ₄	L ₂	n ₁	i ₂	s ₂	s ₃	Order number	Material number	
											1.0460	1.4571
3	6	1,5	M 14x1,5	¼ NPT	59	34	15	19	19	M2B 3 NPT		
4	8	2	M 16x1,5	¼ NPT	59	34	15	19	22	M2B 4 NPT		
6	10	2	M 18x1,5	3/8 NPT	60	35	15	22	22	M2B 6 NPT		
8	12	2	M 20x1,5	3/8 NPT	62	35	15	22	24	M2B 8 NPT		
10	13,5	1,75	M 22x1,5	½ NPT	75	44	20	27	27	M2B 10 NPT		
12	16	2,5	M 24x1,5	½ NPT	75	44	20	27	30	M2B 12 NPT		
16	20	2,5	M 30x2	¾ NPT	84	48	20	32	36	M2B 16 NPT		
20	25	2,5	M 36x2	1 NPT	99	58	25	41	46	M2B 20 NPT		
25	30	3	M 42x2	1 ¼ NPT	106	62	25,5	50	50	M2B 25 NPT		
32	38	3,5	M 52x2	1 ½ NPT	116	66	26	55	60	M2B 32 NPT		
40	44	4,25	M 56x2	2 NPT	126	71	27	65	65	M2B 40 NPT		
50	57	6	M 68x2	2 NPT	133	73	27	70	80	M2B 50 NPT		

J2B-NPT Series for pressures up to PN 250:

DN	d ₁	s	d ₃	d ₄	L ₂	n ₁	i ₂	s ₂	s ₃	Order number	Material number	
											1.0460	1.4571
3	6	1,5	M 14x1,5	¼ NPT	59	34	15	19	19	J2B 3 NPT		
4	8	2	M 16x1,5	¼ NPT	59	34	15	19	22	J2B 4 NPT		
6	10	2	M 18x1,5	3/8 NPT	60	35	15	22	22	J2B 6 NPT		
8	12	2	M 20x1,5	3/8 NPT	62	35	15	22	24	J2B 8 NPT		
10	13,5	1,75	M 22x1,5	½ NPT	75	44	20	27	27	J2B 10 NPT		
12	17	2,5	M 24x1,5	½ NPT	77	46	20	27	30	J2B 12 NPT		
16	21	2,5	M 30x2	¾ NPT	86	50	20	32	36	J2B 16 NPT		
20	27	3,5	M 36x2	1 NPT	99	58	25	41	46	J2B 20 NPT		
25	34	4,5	M 45x2	1 ¼ NPT	107	63	25,5	50	55	J2B 25 NPT		
32	42	4	M 52x2	1 ½ NPT	118	66	26	55	60	J2B 32 NPT		
40	50	5,5	M 64x2	2 NPT	129	73	27	65	75	J2B 40 NPT		

M3B-NPT Series for pressures up to PN 320:

DN	d ₁	s	d ₃	d ₄	L ₂	n ₁	i ₂	s ₂	s ₃	Order number	Material number	
											1.0460	1.4571
3	6	1,5	M 14x1,5	¼ NPT	59	34	15	19	19	M3B 3 NPT		
4	8	2	M 16x1,5	¼ NPT	59	34	15	19	22	M3B 4 NPT		
5	10	2,5	M 18x1,5	3/8 NPT	60	35	15	22	24	M3B 5 NPT		
6	12	3	M 20x1,5	3/8 NPT	66	37	15	22	27	M3B 6 NPT		
8	13,5	2,75	M 22x1,5	½ NPT	75	44	20	27	30	M3B 8 NPT		
10	16	3	M 24x1,5	½ NPT	81	46	20	27	32	M3B 10 NPT		
12	20	4	M 30x2	¾ NPT	90	50	20	32	36	M3B 12 NPT		
16	25	4,5	M 36x2	1 NPT	103	60	25	41	46	M3B 16 NPT		
20	30	5	M 42x2	1 ¼ NPT	112	64	25,5	50	50	M3B 20 NPT		
25a	35	5,5	M 48x2	1 ½ NPT	119	68	26	55	55	M3B 25a NPT		
25	38	6	M 52x2	1 ½ NPT	122	68	26	55	60	M3B 25 NPT		
32	44	6,75	M 60x2	2 NPT	134	73	27	65	70	M3B 32 NPT		

J3B-NPT Series for pressures up to PN 320:

DN	d ₁	s	d ₃	d ₄	L ₂	n ₁	i ₂	s ₂	s ₃	Order number	Material number	
											1.0460	1.4571
3	6	1,5	M 14x1,5	¼ NPT	59	34	15	19	19	J3B 3 NPT		
4	8	2	M 16x1,5	¼ NPT	59	34	15	19	22	J3B 4 NPT		
5	10	2,5	M 18x1,5	3/8 NPT	60	35	15	22	24	J3B 5 NPT		
6	12	3	M 20x1,5	3/8 NPT	66	37	15	22	27	J3B 6 NPT		
8	13,5	2,75	M 22x1,5	½ NPT	75	44	20	27	30	J3B 8 NPT		
10	17	3	M 27x2	½ NPT	87	52	20	30	36	J3B 10 NPT		
12	21	4	M 33x2	¾ NPT	95	55	20	36	41	J3B 12 NPT		
16	27	4,5	M 39x2	1 NPT	107	64	25	41	46	J3B 16 NPT		
20	34	5,5	M 48x2	1 ¼ NPT	119	70	25,5	50	55	J3B 20 NPT		
25	42	7	M 56x2	1 ½ NPT	127	73	26	60	65	J3B 25 NPT		
32	48	6,5	M 64x2	2 NPT	138	77	27	65	70	J3B 32 NPT		

For orders on individual parts we need the following information:

Pieces	Component	Designation	Order number	Material number
1	1	Weld-on stub	(Series)-(DN)- 1	_____
1	2	Clamping nut	(Series)-(DN)- 2	_____
1	5 NPT	Screw-in stub	(Series)-(DN)- 5 NPT	_____

Materials: see „Material standards“ page 6

Angle unions



Elbow DILO tube unions can be used for 90° angles. Angle unions are available with weld-on ends for applications where highest vibration resistance is required. They are also available with weld-on end and Whitworth screw-in thread.

Throttle-free swivel unions allow positioning of the weld-on end as per your requirements. Thus, any tubing can be established, no matter how complex they are.

Temperature resistance of all unions from -270 °C up to +500 °C, depending on the material used.

■ Angle unions

- Angle weld-on unions 32
- Angle screw-in unions with Whitworth thread 34
- Throttlefree angle-swivel unions with Whitworth thread 36

Angle weld-on unions



- With weld-on ends
- 90° angle
- Available for tube diameters from DN 3 up to DN 50
- Temperature-resistant from -270 °C up to +500 °C (dependant on the material used)
- Available for pressures up to 1.000 bar on request
- Available in DIN EN materials: 1.0460 and 1.4571 Other materials on request.
- Five-part union consisting of 2 weld-on stubs, 2 clamping nuts und 1 angle piece

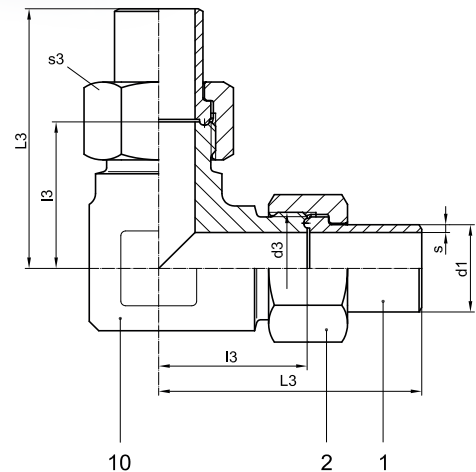

M1AW Series for pressures up to PN 100:

DN	d ₁	s	d ₃	L ₃	l ₃	s ₃	Order number	Material number	
								1.0460	1.4571
4	6	1,25	M 14x1,5	42	21	17	M1AW 4		
6	8	1,5	M 16x1,5	50	27	19	M1AW 6		
8	10	1,5	M 18x1,5	52	27	22	M1AW 8		
10	12	1,75	M 20x1,5	57	30	24	M1AW 10		
12	15	2	M 22x1,5	60	31	27	M1AW 12		
16	18	2	M 26x1,5	64	33	32	M1AW 16		
20	22	2	M 30x1,5	68	35	36	M1AW 20		
25	28	2,5	M 36x2	84	47	41	M1AW 25		
32	35	2,5	M 45x2	94	54	50	M1AW 32		
40a	42	3	M 52x2	105	62	60	M1AW 40a		
40	44	3	M 56x2	111	68	65	M1AW 40		
50	57	4	M 68x2	128	80	75	M1AW 50		

 Parts available from stock

M2AW Series for pressures up to PN 200:

DN	d ₁	s	d ₃	L ₃	l ₃	s ₃	Order number	Material number	
								1.0460	1.4571
3	6	1,5	M 14x1,5	48	23	19	M2AW 3		
4	8	2	M 16x1,5	52	27	22	M2AW 4		
6	10	2	M 18x1,5	52	27	22	M2AW 6		
8	12	2	M 20x1,5	56	29	24	M2AW 8		
10	13,5	1,75	M 22x1,5	62	31	27	M2AW 10		
12	16	2,5	M 24x1,5	64	33	30	M2AW 12		
16	20	2,5	M 30x2	70	34	36	M2AW 16		
20	25	2,5	M 36x2	89	48	46	M2AW 20		
25	30	3	M 42x2	98	54	50	M2AW 25		
32	38	3,5	M 52x2	112	62	60	M2AW 32		
40	44	4,25	M 56x2	123	68	65	M2AW 40		
50	57	6	M 68x2	140	80	80	M2AW 50		

M3AW Series for pressures up to PN 320:

DN	d ₁	s	d ₃	L ₃	l ₃	s ₃	Order number	Material number	
								1.0460	1.4571
3	6	1,5	M 14x1,5	48	23	19	M3AW 3		
4	8	2	M 16x1,5	52	27	22	M3AW 4		
5	10	2,5	M 18x1,5	52	27	24	M3AW 5		
6	12	3	M 20x1,5	59	30	27	M3AW 6		
8	13,5	2,75	M 22x1,5	63	32	30	M3AW 8		
10	16	3	M 24x1,5	68	33	32	M3AW 10		
12	20	4	M 30x2	74	35	36	M3AW 12		
16	25	4,5	M 36x2	92	49	46	M3AW 16		
20	30	5	M 42x2	104	56	50	M3AW 20		
25a	35	5,5	M 48x2	112	61	55	M3AW 25a		
25	38	6	M 52x2	118	64	60	M3AW 25		
32	44	6,75	M 60x2	134	73	70	M3AW 32		

For orders on individual parts we need the following information:

Pieces	Component	Designation	Order number	Material number
2	1	Weld-on stub	(Series)-(DN)- 1	_____
2	2	Clamping nut	(Series)-(DN)- 2	_____
1	10	Angle	(Series)-(DN)- 10	_____

Materials: see „Material standards“ page 6

Angle screw-in unions

with Whitworth thread

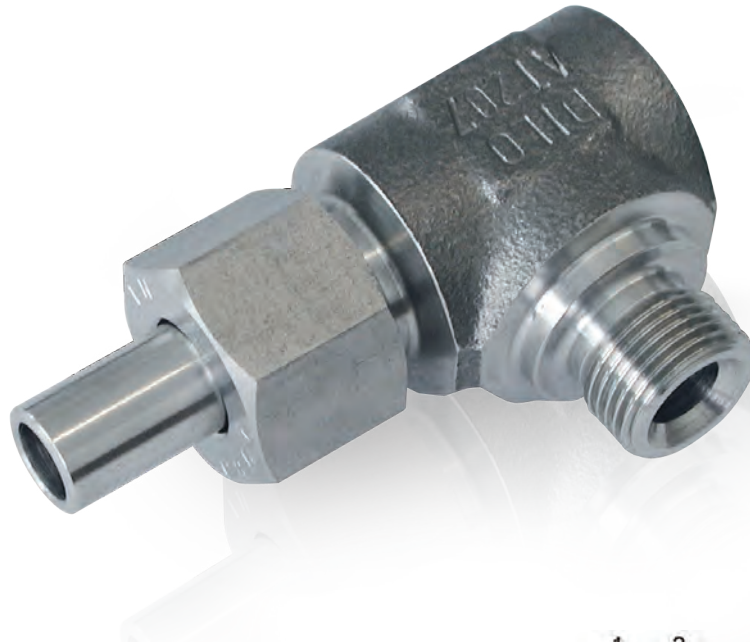

- With weld-on end and screw-in thread
- 90° angle
- Available for tube diameters from DN 3 up to DN 50
- Temperature-resistant from -270 °C up to +500 °C (dependant on the material used)
- Available for pressures up to 1.000 bar on request
- Available in DIN EN materials: 1.0460 and 1.4571
Other materials on request.
- Three-part union consisting of weld-on stub, clamping nut und screw-in angle

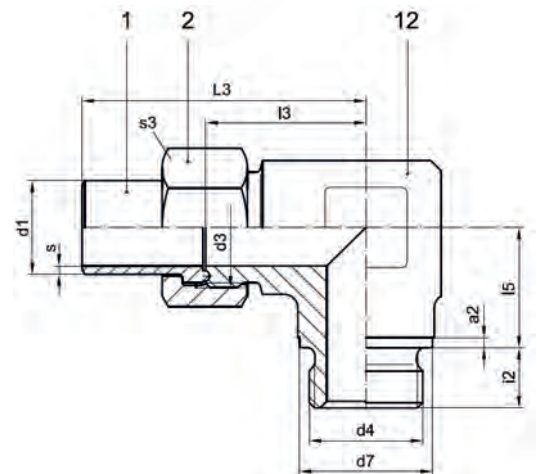

M1BW-G Series for pressures up to PN 100:

DN	d ₁	s	d ₃	d ₄	d ₇	L ₃	l ₃	l ₅	i ₂	a ₂	s ₃	Order number	Material number	
													1.0460	1.4571
4	6	1,25	M 14x1,5	G 1/8 A	14	42	21	16	8	1,5	17	M1BW 4 G		
6	8	1,5	M 16x1,5	G 1/4 A	18	50	27	18	12	2	19	M1BW 6 G		
8	10	1,5	M 18x1,5	G 1/4 A	18	52	27	18	12	2	22	M1BW 8 G		
10	12	1,75	M 20x1,5	G 3/8 A	22	57	30	19	12	2,5	24	M1BW 10 G		
12	15	2	M 22x1,5	G 1/2 A	26	60	31	20	14	3	27	M1BW 12 G		
16	18	2	M 26x1,5	G 1/2 A	26	64	33	23	14	3	32	M1BW 16 G		
20	22	2	M 30x1,5	G 3/4 A	32	68	35	28	16	3	36	M1BW 20 G		
25	28	2,5	M 36x2	G 1 A	39	84	47	36	18	3	41	M1BW 25 G		
32	35	2,5	M 45x2	G 1 1/4 A	49	94	54	34	20	3	50	M1BW 32 G		
40a	42	3	M 52x2	G 1 1/2 A	55	105	62	40	22	3	60	M1BW 40a G		
40	44	3	M 56x2	G 1 1/2 A	55	111	68	46	22	3	65	M1BW 40 G		
50	57	4	M 68x2	G 2 A	68	128	80	56	24	3,5	75	M1BW 50 G		

M2BW-G Series for pressures up to PN 200:

DN	d ₁	s	d ₃	d ₄	d ₇	L ₃	l ₃	l ₅	i ₂	a ₂	s ₃	Order number	Material number	
													1.0460	1.4571
3	6	1,5	M 14x1,5	G ¼ A	18	48	23	13	12	2	19	M2BW 3 G		
4	8	2	M 16x1,5	G ¼ A	18	52	27	19	12	2	22	M2BW 4 G		
6	10	2	M 18x1,5	G 3/8 A	22	52	27	19	12	2,5	22	M2BW 6 G		
8	12	2	M 20x1,5	G 3/8 A	22	56	29	21	12	2,5	24	M2BW 8 G		
10	13,5	1,75	M 22x1,5	G ½ A	26	62	31	21	14	3	27	M2BW 10 G		
12	16	2,5	M 24x1,5	G ½ A	26	64	33	25	14	3	30	M2BW 12 G		
16	20	2,5	M 30x2	G ¾ A	32	70	34	29	16	3	36	M2BW 16 G		
20	25	2,5	M 36x2	G 1 A	39	89	48	36	18	3	46	M2BW 20 G		
25	30	3	M 42x2	G 1 ¼ A	49	98	54	34	20	3	50	M2BW 25 G		
32	38	3,5	M 52x2	G 1 ½ A	55	112	62	40	22	3	60	M2BW 32 G		
40	44	4,25	M 56x2	G 1 ¾ A	62	123	68	44	24	3,5	65	M2BW 40 G		
50	57	6	M 68x2	G 2 A	68	140	80	56	24	3,5	80	M2BW 50 G		

M3BW-G Series for pressures up to PN 320:

DN	d ₁	s	d ₃	d ₄	d ₇	L ₃	l ₃	l ₅	i ₂	a ₂	s ₃	Order number	Material number	
													1.0460	1.4571
3	6	1,5	M 14x1,5	G ¼ A	18	48	23	14	12	2	19	M3BW 3 G		
4	8	2	M 16x1,5	G ¼ A	18	52	27	19	12	2	22	M3BW 4 G		
5	10	2,5	M 18x1,5	G 3/8 A	22	52	27	19	12	2,5	24	M3BW 5 G		
6	12	3	M 20x1,5	G 3/8 A	22	59	30	21	12	2,5	27	M3BW 6 G		
8	13,5	2,75	M 22x1,5	G ½ A	26	63	32	21	14	3	30	M3BW 8 G		
10	16	3	M 24x1,5	G ½ A	26	68	33	25	14	3	32	M3BW 10 G		
12	20	4	M 30x2	G ¾ A	32	74	35	29	16	3	36	M3BW 12 G		
16	25	4,5	M 36x2	G 1 A	39	92	49	36	18	3	46	M3BW 16 G		
20	30	5	M 42x2	G 1 ¼ A	49	104	56	34	20	3	50	M3BW 20 G		
25a	35	5,5	M 48x2	G 1 ½ A	55	112	61	37	22	3	55	M3BW 25a G		
25	38	6	M 52x2	G 1 ½ A	55	118	64	40	22	3	60	M3BW 25 G		
32	44	6,75	M 60x2	G 1 ¾ A	62	134	73	47	24	3,5	70	M3BW 32 G		

For orders on individual parts we need the following information:

Pieces	Component	Designation	Order number	Material number
1	1	Weld-on stub	(Series)-(DN)- 1	_____
1	2	Clamping nut	(Series)-(DN)- 2	_____
1	12	Screw-in angle	(Series)-(DN)- 12	_____

Materials: see „Material standards“ page 6

Accessories: copper seals
see page 66



Throttlefree angle-swivel unions with Whitworth thread



- With weld-on end (adjustable)
- Available for tube diameters from DN 3 up to DN 40
- Temperature-resistant from -270 °C up to +500 °C (dependant on the material used)
- Available in DIN EN materials: 1.0460 and 1.4571
Other materials on request.
- Four-part union consisting of weld-on stub, clamping nut, screw-in stub and angle-swivel piece

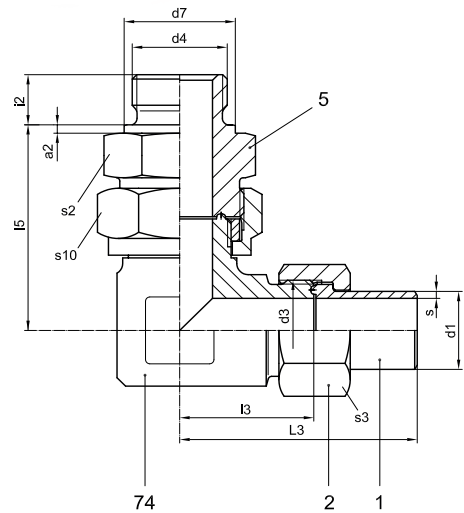

SD1W-G Series for pressures up to PN 100:

DN	d ₁	s	d ₃	d ₄	d ₇	L ₃	l ₃	l ₅	i ₂	a ₂	s ₂	s ₃	s ₁₀	Order number	Material number	
															1.0460	1.4571
4	6	1,25	M 14x1,5	G 1/8 A	14	42	21	42	8	1,5	24	17	27	SD1W 4 G		
6	8	1,5	M 16x1,5	G 1/4 A	18	50	27	44	12	2	27	19	30	SD1W 6 G		
8	10	1,5	M 18x1,5	G 1/4 A	18	52	27	47,5	12	2	27	22	32	SD1W 8 G		
10	12	1,75	M 20x1,5	G 3/8 A	22	57	30	52	12	2,5	32	24	36	SD1W 10 G		
12	15	2	M 22x1,5	G 1/2 A	26	60	31	54	14	3	32	27	36	SD1W 12 G		
16	18	2	M 26x1,5	G 1/2 A	26	64	33	61	14	3	41	32	41	SD1W 16 G		
20	22	2	M 30x1,5	G 3/4 A	32	69	35	71	16	3	46	36	46	SD1W 20 G		
25	28	2,5	M 36x2	G 1 A	39	84	47	74	18	3	46	41	50	SD1W 25 G		
32	35	2,5	M 45x2	G 1 1/4 A	49	94	54	78	20	3	55	50	60	SD1W 32 G		
40a	42	3	M 52x2	G 1 1/2 A	55	105	62	83	22	3	60	60	65	SD1W 40a G		

Parts available from stock

SD2W-G Series for pressures up to PN 200:

DN	d ₁	s	d ₃	d ₄	d ₇	L ₃	l ₃	l ₅	i ₂	a ₂	s ₂	s ₃	s ₁₀	Order number	Material number	
															1.0460	1.4571
3	6	1,5	M 14x1,5	G ¼ A	18	49	23	43	12	2	24	19	27	SD2W 3 G		
4	8	2	M 16x1,5	G ¼ A	18	53	27	43	12	2	24	22	27	SD2W 4 G		
6	10	2	M 18x1,5	G 3/8 A	22	53	27	45	12	2,5	27	22	30	SD2W 6 G		
8	12	2	M 20x1,5	G 3/8 A	22	57	29	51	12	2,5	30	24	32	SD2W 8 G		
10	13,5	1,75	M 22x1,5	G ½ A	26	63	31	55	14	3	32	27	36	SD2W 10 G		
12	16	2,5	M 24x1,5	G ½ A	26	65	33	61	14	3	36	30	41	SD2W 12 G		
16	20	2,5	M 30x1,5	G ¾ A	32	71	34	70	16	3	41	36	46	SD2W 16 G		
20	25	2,5	M 36x2	G 1 A	39	90	48	72	18	3	46	46	50	SD2W 20 G		
25	30	3	M 42x2	G 1 ¼ A	49	98	53	80	20	3	50	50	55	SD2W 25 G		
32	38	3,5	M 52x2	G 1 ½ A	55	112	61	86	22	3	60	60	65	SD2W 32 G		

SD3W-G Series for pressures up to PN 320:

DN	d ₁	s	d ₃	d ₄	d ₇	L ₃	l ₃	l ₅	i ₂	a ₂	s ₂	s ₃	s ₁₀	Order number	Material number	
															1.0460	1.4571
3	6	1,5	M 14x1,5	G ¼ A	18	48	23	44	12	2	24	19	27	SD3W 3 G		
4	8	2	M 16x1,5	G ¼ A	18	52	27	44	12	2	24	22	27	SD3W 4 G		
5	10	2,5	M 18x1,5	G 3/8 A	22	52	27	49	12	2,5	27	24	30	SD3W 5 G		
6	12	3	M 20x1,5	G 3/8 A	22	59	30	50	12	2,5	27	27	30	SD3W 6 G		
8	13,5	2,75	M 22x1,5	G ½ A	26	63	32	55	14	3	30	30	36	SD3W 8 G		
10	16	3	M 24x1,5	G ½ A	26	68	33	58	14	3	32	32	36	SD3W 10 G		
12	20	4	M 30x1,5	G ¾ A	32	74	35	69	16	3	36	36	41	SD3W 12 G		
16	25	4,5	M 36x2	G 1 A	39	92	49	72	18	3	46	46	50	SD3W 16 G		
20	30	5	M 42x2	G 1 ¼ A	49	104	56	79	20	3	50	50	55	SD3W 20 G		
25a	35	5,5	M 48x2	G 1 ½ A	55	114	63	87	22	3	60	55	65	SD3W 25a G		
25	38	6	M 52x2	G 1 ½ A	55	117	63	87	22	3	60	60	65	SD3W 25 G		

For orders on individual parts we need the following information:

Pieces	Component	Designation	Order number	Material number
1	1	Weld-on stub	(M-Series)-(DN)- 1	_____
1	2	Clamping nut	(M-Series)-(DN)- 2	_____
1	5	Screw-in stub	(SD-Series)-(DN)- 5	_____
1	74	Angle-swivel piece	(SD-Series)-(DN)-74	_____

Materials: see „Material standards“ page 6

Accessories: copper seals
see page 66



Tee and L-Unions

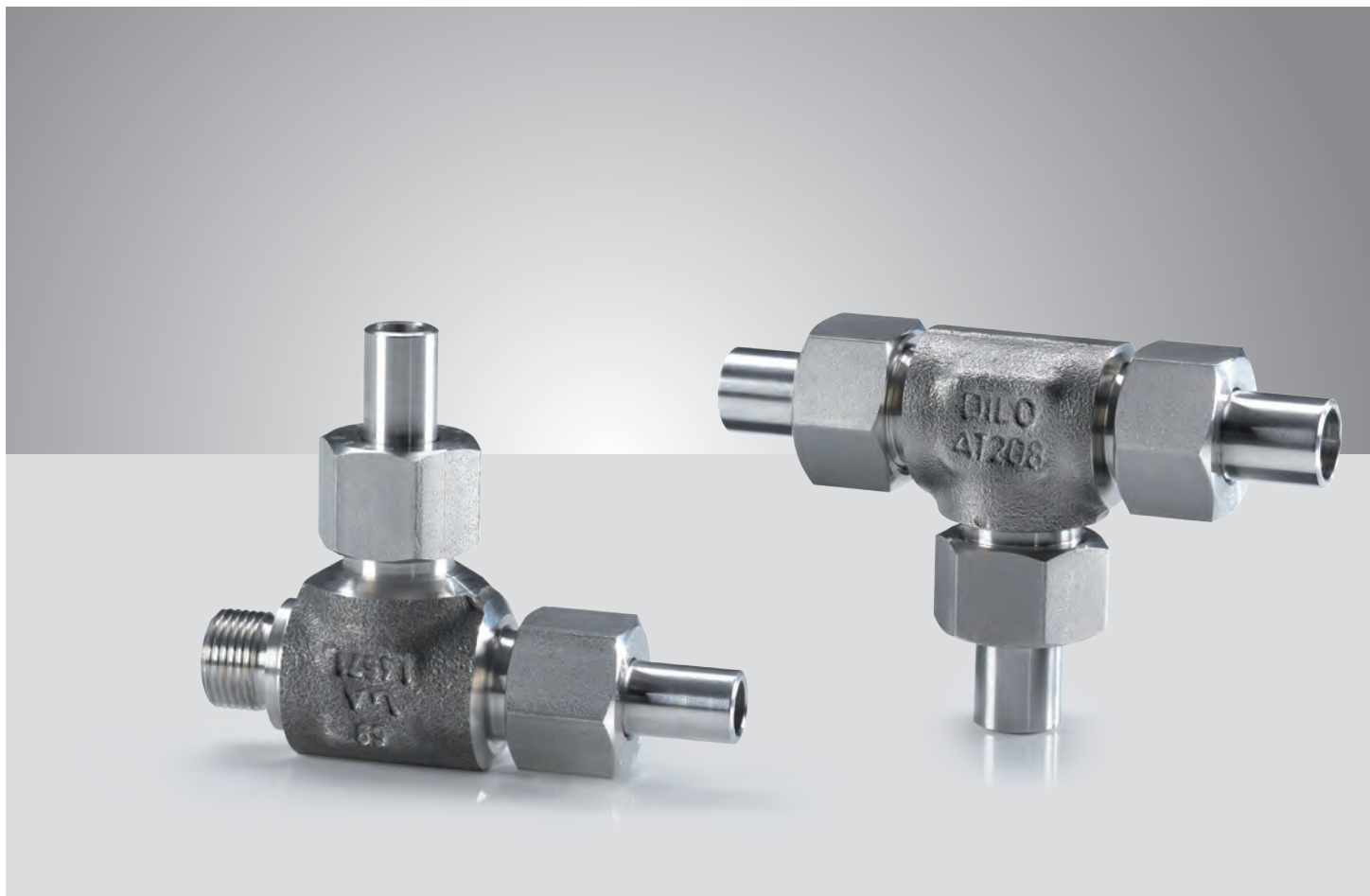

Tee or L-shaped DILO tube unions allow flexibility in tubing construction. Both versions are available with weld-on end for applications where highest vibration resistance is required or combined with a Whitworth screw-in thread which enables more variability in use.

Temperature resistance from -270 °C up to +500 °C, depending on the material used.

■ Tee and L-Unions

- Tee weld-on unions 40
- Tee screw-in unions with Whitworth thread 42
- L-screw-in unions with Whitworth thread 44
- Throttlefree Tee swivel unions with Whitworth thread 46
- Throttlefree L-swivel unions with Whitworth thread 48

Tee weld-on unions



- With three weld-on ends
- Available for tube diameters from DN 3 up to DN 50
- Temperature-resistant from -270 °C up to +500 °C (dependant on the material used)
- Available for pressures up to 1.000 bar on request
- Available in DIN EN materials: 1.0460 and 1.4571
Other materials on request.
- Seven-part union consisting of 3 weld-on stubs, 3 clamping nuts and 1 Tee-piece

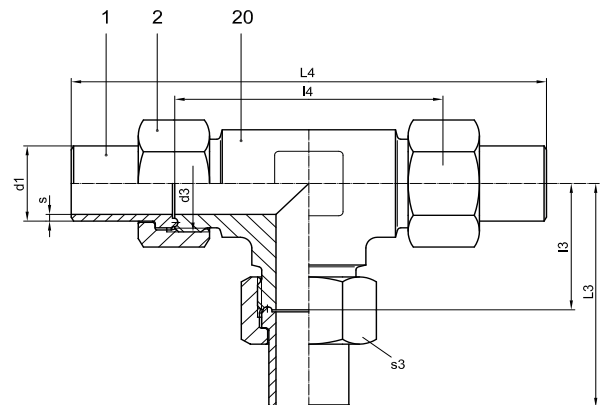

M1AT Series for pressures up to PN 100:

DN	d ₁	s	d ₃	L ₃	l ₃	L ₄	l ₄	s ₃	Order number	Material number	
										1.0460	1.4571
4	6	1,25	M 14x1,5	42	21	83	42	17	M1AT 4		
6	8	1,5	M 16x1,5	50	27	99	54	19	M1AT 6		
8	10	1,5	M 18x1,5	52	27	103	54	22	M1AT 8		
10	12	1,75	M 20x1,5	57	30	113	60	24	M1AT 10		
12	15	2	M 22x1,5	60	31	119	62	27	M1AT 12		
16	18	2	M 26x1,5	64	33	127	66	32	M1AT 16		
20	22	2	M 30x1,5	68	35	135	69	36	M1AT 20		
25	28	2,5	M 36x2	84	47	167	94	41	M1AT 25		
32	35	2,5	M 45x2	94	54	187	108	50	M1AT 32		
40a	42	3	M 52x2	105	62	209	124	60	M1AT 40a		
40	44	3	M 56x2	111	68	221	136	65	M1AT 40		
50	57	4	M 68x2	128	80	255	160	75	M1AT 50		

 Parts available from stock

M2AT Series for pressures up to PN 200:

DN	d ₁	s	d ₃	L ₃	l ₃	L ₄	l ₄	s ₃	Order number	Material number	
										1.0460	1.4571
3	6	1,5	M 14x1,5	48	23	96	46	19	M2AT 3		
4	8	2	M 16x1,5	52	27	104	54	22	M2AT 4		
6	10	2	M 18x1,5	52	27	104	54	22	M2AT 6		
8	12	2	M 20x1,5	56	29	112	58	24	M2AT 8		
10	13,5	1,75	M 22x1,5	62	31	124	62	27	M2AT 10		
12	16	2,5	M 24x1,5	64	33	128	66	30	M2AT 12		
16	20	2,5	M 30x2	70	34	140	68	36	M2AT 16		
20	25	2,5	M 36x2	89	48	178	96	46	M2AT 20		
25	30	3	M 42x2	98	54	196	108	50	M2AT 25		
32	38	3,5	M 52x2	112	62	224	124	60	M2AT 32		
40	44	4,25	M 56x2	123	68	246	136	65	M2AT 40		
50	57	6	M 68x2	140	80	280	160	80	M2AT 50		

M3AT Series for pressures up to PN 320:

DN	d ₁	s	d ₃	L ₃	l ₃	L ₄	l ₄	s ₃	Order number	Material number	
										1.0460	1.4571
3	6	1,5	M 14x1,5	48	23	96	46	19	M3AT 3		
4	8	2	M 16x1,5	52	27	104	54	22	M3AT 4		
5	10	2,5	M 18x1,5	52	27	104	54	24	M3AT 5		
6	12	3	M 20x1,5	59	30	118	60	27	M3AT 6		
8	13,5	2,75	M 22x1,5	63	32	126	64	30	M3AT 8		
10	16	3	M 24x1,5	68	33	136	66	32	M3AT 10		
12	20	4	M 30x2	74	35	148	70	36	M3AT 12		
16	25	4,5	M 36x2	92	49	184	98	46	M3AT 16		
20	30	5	M 42x2	104	56	208	112	50	M3AT 20		
25a	35	5,5	M 48x2	112	61	224	122	55	M3AT 25a		
25	38	6	M 52x2	118	64	236	128	60	M3AT 25		
32	44	6,75	M 60x2	134	73	268	146	70	M3AT 32		

For orders on individual parts we need the following information:

Pieces	Component	Designation	Order number	Material number
3	1	Weld-on stub	(Series)-(DN)- 1	_____
3	2	Clamping nut	(Series)-(DN)- 2	_____
1	20	Tee piece	(Series)-(DN)- 20	_____

Materials: see „Material standards“ page 6

Tee screw-in unions

with Whitworth thread



- With two weld-on ends and one screw-in thread
- Available for tube diameters from DN 3 up to DN 50
- Temperature-resistant from -270 °C up to +500 °C (dependant on the material used)
- Available in DIN EN materials: 1.0460 and 1.4571
Other materials on request.
- Five-part union consisting of 2 weld-on stubs, 2 clamping nuts and 1 screw-in Tee piece

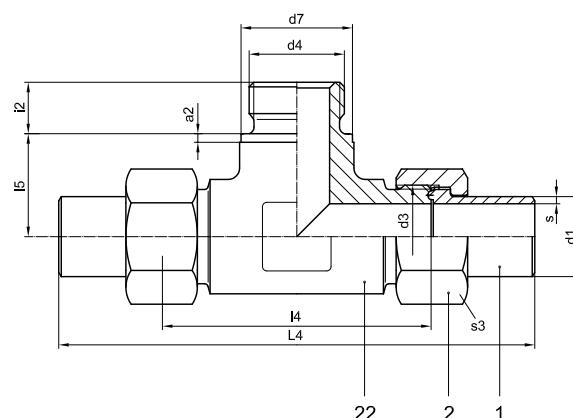

M1BT-G Series for pressures up to PN 100:

DN	d ₁	s	d ₃	d ₄	d ₇	L ₄	L ₄	L ₅	i ₂	a ₂	s ₃	Order number	Material number	
													1.0460	1.4571
4	6	1,25	M 14x1,5	G 1/8 A	14	83	42	16	8	1,5	17	M1BT 4 G		
6	8	1,5	M 16x1,5	G 1/4 A	18	99	54	18	12	2	19	M1BT 6 G		
8	10	1,5	M 18x1,5	G 1/4 A	18	103	54	18	12	2	22	M1BT 8 G		
10	12	1,75	M 20x1,5	G 3/8 A	22	113	60	19	12	2,5	24	M1BT 10 G		
12	15	2	M 22x1,5	G 1/2 A	26	119	62	20	14	3	27	M1BT 12 G		
16	18	2	M 26x1,5	G 1/2 A	26	127	66	23	14	3	32	M1BT 16 G		
20	22	2	M 30x1,5	G 3/4 A	32	135	69	28	16	3	36	M1BT 20 G		
25	28	2,5	M 36x2	G 1 A	39	167	94	36	18	3	41	M1BT 25 G		
32	35	2,5	M 45x2	G 1 1/4 A	49	187	108	34	20	3	50	M1BT 32 G		
40a	42	3	M 52x2	G 1 1/2 A	55	209	124	40	22	3	60	M1BT 40a G		
40	44	3	M 56x2	G 1 1/2 A	55	221	136	46	22	3	65	M1BT 40 G		
50	57	4	M 68x2	G 2 A	68	255	160	56	24	3,5	75	M1BT 50 G		

M2BT-G Series for pressures up to PN 200:

DN	d ₁	s	d ₃	d ₄	d ₇	L ₄	l ₄	l ₅	i ₂	a ₂	s ₃	Order number	Material number	
													1.0460	1.4571
3	6	1,5	M 14x1,5	G ¼ A	18	96	46	13	12	2	19	M2BT 3 G		
4	8	2	M 16x1,5	G ¼ A	18	104	54	19	12	2	22	M2BT 4 G		
6	10	2	M 18x1,5	G 3/8 A	22	104	54	19	12	2,5	22	M2BT 6 G		
8	12	2	M 20x1,5	G 3/8 A	22	112	58	21	12	2,5	24	M2BT 8 G		
10	13,5	1,75	M 22x1,5	G ½ A	26	124	62	21	14	3	27	M2BT 10 G		
12	16	2,5	M 24x1,5	G ½ A	26	128	66	25	14	3	30	M2BT 12 G		
16	20	2,5	M 30x2	G ¾ A	32	140	68	29	16	3	36	M2BT 16 G		
20	25	2,5	M 36x2	G 1 A	39	178	96	36	18	3	46	M2BT 20 G		
25	30	3	M 42x2	G 1 ¼ A	49	196	108	34	20	3	50	M2BT 25 G		
32	38	3,5	M 52x2	G 1 ½ A	55	224	124	40	22	3	60	M2BT 32 G		
40	44	4,25	M 56x2	G 1 ¾ A	62	246	136	44	24	3,5	65	M2BT 40 G		
50	57	6	M 68x2	G 2 A	68	280	160	56	24	3,5	80	M2BT 50 G		

M3BT-G Series for pressures up to PN 320:

DN	d ₁	s	d ₃	d ₄	d ₇	L ₄	l ₄	l ₅	i ₂	a ₂	s ₃	Order number	Material number	
													1.0460	1.4571
3	6	1,5	M 14x1,5	G ¼ A	18	96	46	14	12	2	19	M3BT 3 G		
4	8	2	M 16x1,5	G ¼ A	18	104	54	19	12	2	22	M3BT 4 G		
5	10	2,5	M 18x1,5	G 3/8 A	22	104	54	19	12	2,5	24	M3BT 5 G		
6	12	3	M 20x1,5	G 3/8 A	22	118	60	21	12	2,5	27	M3BT 6 G		
8	13,5	2,75	M 22x1,5	G ½ A	26	126	64	21	14	3	30	M3BT 8 G		
10	16	3	M 24x1,5	G ½ A	26	136	66	25	14	3	32	M3BT 10 G		
12	20	4	M 30x2	G ¾ A	32	148	70	29	16	3	36	M3BT 12 G		
16	25	4,5	M 36x2	G 1 A	39	184	98	36	18	3	46	M3BT 16 G		
20	30	5	M 42x2	G 1 ¼ A	49	208	112	34	20	3	50	M3BT 20 G		
25a	35	5,5	M 48x2	G 1 ½ A	55	224	122	37	22	3	55	M3BT 25a G		
25	38	6	M 52x2	G 1 ½ A	55	236	128	40	22	3	60	M3BT 25 G		
32	44	6,75	M 60x2	G 1 ¾ A	62	268	146	47	24	3,5	70	M3BT 32 G		

For orders on individual parts we need the following information:

Pieces	Component	Designation	Order number	Material number
2	1	Weld-on stub	(Series)-(DN)- 1	_____
2	2	Clamping nut	(Series)-(DN)- 2	_____
1	22	Screw-in Tee piece	(Series)-(DN)- 22	_____

Materials: see „Material standards“ page 6

Accessories: copper seals
see page 66



L-screw-in unions

with Whitworth thread

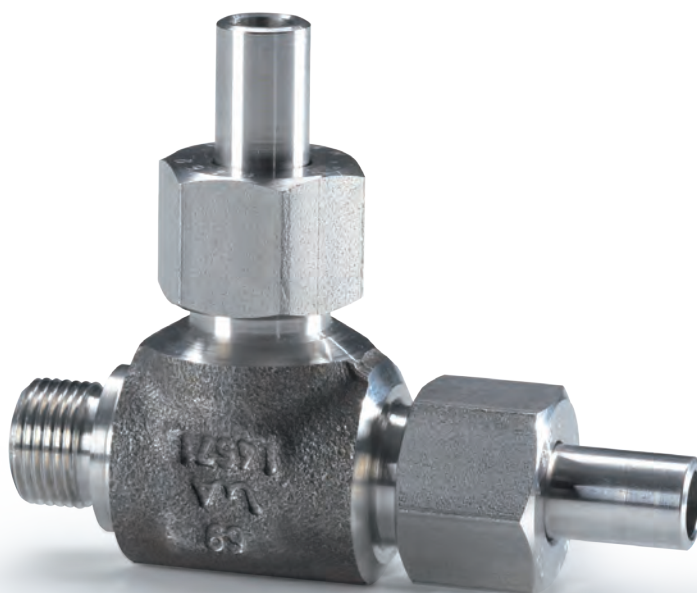

- With two weld-on ends and one screw-in thread
- Available for tube diameters from DN 3 up to DN 50
- Temperature-resistant from -270 °C up to +500 °C (dependant on the material used)
- Available in DIN EN materials: 1.0460 and 1.4571
Other materials on request.
- Five-part union consisting of 2 weld-on stubs, 2 clamping nuts and 1 screw-in L piece

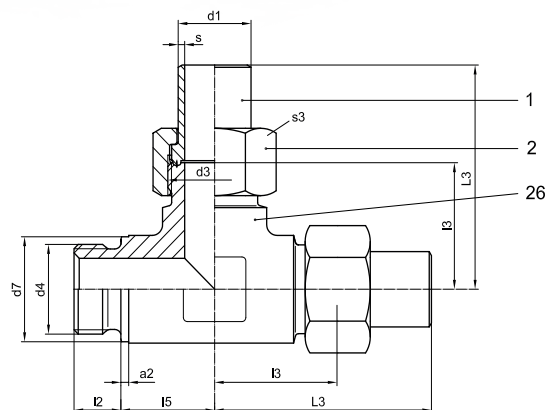

M1BL-G Series for pressures up to PN 100:

DN	d ₁	s	d ₃	d ₄	d ₇	L ₃	l ₃	l ₅	i ₂	a ₂	s ₃	Order number	Material number	
													1.0460	1.4571
4	6	1,25	M 14x1,5	G 1/8 A	14	42	21	16	8	1,5	17	M1BL 4 G		
6	8	1,5	M 16x1,5	G 1/4 A	18	50	27	18	12	2	19	M1BL 6 G		
8	10	1,5	M 18x1,5	G 1/4 A	18	52	27	18	12	2	22	M1BL 8 G		
10	12	1,75	M 20x1,5	G 3/8 A	22	57	30	19	12	2,5	24	M1BL 10 G		
12	15	2	M 22x1,5	G 1/2 A	26	60	31	19	14	3	27	M1BL 12 G		
16	18	2	M 26x1,5	G 1/2 A	26	64	33	23	14	3	32	M1BL 16 G		
20	22	2	M 30x1,5	G 3/4 A	32	68	35	28	16	3	36	M1BL 20 G		
25	28	2,5	M 36x2	G 1 A	39	84	47	36	18	3	41	M1BL 25 G		
32	35	2,5	M 45x2	G 1 1/4 A	49	94	54	34	20	3	50	M1BL 32 G		
40a	42	3	M 52x2	G 1 1/2 A	55	105	62	40	22	3	60	M1BL 40a G		
40	44	3	M 56x2	G 1 1/2 A	55	111	68	46	22	3	65	M1BL 40 G		
50	57	4	M 68x2	G 2 A	68	128	80	56	24	3,5	75	M1BL 50 G		

M2BL-G Series for pressures up to PN 200:

DN	d ₁	s	d ₃	d ₄	d ₇	L ₃	l ₃	l ₅	i ₂	a ₂	s ₃	Order number	Material number	
													1.0460	1.4571
3	6	1,5	M 14x1,5	G ¼ A	18	48	23	13	12	2	19	M2BL 3 G		
4	8	2	M 16x1,5	G ¼ A	18	52	27	19	12	2	22	M2BL 4 G		
6	10	2	M 18x1,5	G 3/8 A	22	52	27	19	12	2,5	22	M2BL 6 G		
8	12	2	M 20x1,5	G 3/8 A	22	56	29	20	12	2,5	24	M2BL 8 G		
10	13,5	1,75	M 22x1,5	G ½ A	26	62	31	21	14	3	27	M2BL 10 G		
12	16	2,5	M 24x1,5	G ½ A	26	64	33	25	14	3	30	M2BL 12 G		
16	20	2,5	M 30x2	G ¾ A	32	70	34	29	16	3	36	M2BL 16 G		
20	25	2,5	M 36x2	G 1 A	39	89	48	36	18	3	46	M2BL 20 G		
25	30	3	M 42x2	G 1 ¼ A	49	98	54	34	20	3	50	M2BL 25 G		
32	38	3,5	M 52x2	G 1 ½ A	55	112	62	40	22	3	60	M2BL 32 G		
40	44	4,25	M 56x2	G 1 ¾ A	62	123	68	44	24	3,5	65	M2BL 40 G		
50	57	6	M 68x2	G 2 A	68	140	80	56	24	3,5	80	M2BL 50 G		

M3BL-G Series for pressures up to PN 320:

DN	d ₁	s	d ₃	d ₄	d ₇	L ₃	l ₃	l ₅	i ₂	a ₂	s ₃	Order number	Material number	
													1.0460	1.4571
3	6	1,5	M 14x1,5	G ¼ A	18	48	23	14	12	2	19	M3BL 3 G		
4	8	2	M 16x1,5	G ¼ A	18	52	27	19	12	2	22	M3BL 4 G		
5	10	2,5	M 18x1,5	G 3/8 A	22	52	27	19	12	2,5	24	M3BL 5 G		
6	12	3	M 20x1,5	G 3/8 A	22	59	30	21	12	2,5	27	M3BL 6 G		
8	13,5	2,75	M 22x1,5	G ½ A	26	63	32	21	14	3	30	M3BL 8 G		
10	16	3	M 24x1,5	G ½ A	26	68	33	25	14	3	32	M3BL 10 G		
12	20	4	M 30x2	G ¾ A	32	74	35	29	16	3	36	M3BL 12 G		
16	25	4,5	M 36x2	G 1 A	39	92	49	36	18	3	46	M3BL 16 G		
20	30	5	M 42x2	G 1 ¼ A	49	104	56	34	20	3	50	M3BL 20 G		
25a	35	5,5	M 48x2	G 1 ½ A	55	112	61	37	22	3	55	M3BL 25a G		
25	38	6	M 52x2	G 1 ½ A	55	118	64	40	22	3	60	M3BL 25 G		
32	44	6,75	M 60x2	G 1 ¾ A	62	134	73	47	24	3,5	70	M3BL 32 G		

For orders on individual parts we need the following information:

Pieces	Component	Designation	Order number	Material number
2	1	Weld-on stub	(Series)-(DN)- 1	_____
2	2	Clamping nut	(Series)-(DN)- 2	_____
1	26	Screw-in L piece	(Series)-(DN)- 26	_____

Materials: see „Material standards“ page 6

Accessories: copper seals
see page 66



Throttlefree Tee swivel unions

with Whitworth thread



- With weld-on end (adjustable)
- Available for tube diameters from DN 3 up to DN 40
- Temperature-resistant from -270 °C up to +500 °C (dependant on the material used)
- Available in DIN EN materials: 1.0460 and 1.4571
Other materials on request.
- Six-part union consisting of 2 weld-on stubs,
2 clamping nuts, 1 screw-in stub and 1 Tee swivel
piece

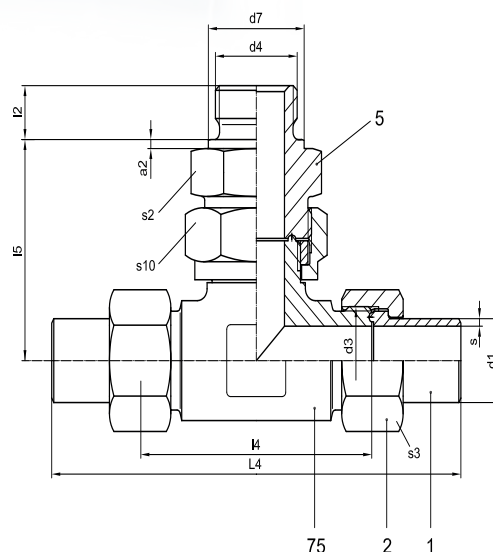

SD1T-G Series for pressures up to PN 100:

DN	d ₁	s	d ₃	d ₄	d ₇	L ₄	L ₄	L ₅	i ₂	a ₂	s ₂	s ₃	s ₁₀	Order number	Material number	
															1.0460	1.4571
4	6	1,25	M 14x1,5	G 1/8 A	14	84	42	42	8	1,5	24	17	27	SD1T 4 G		
6	8	1,5	M 16x1,5	G ¼ A	18	100	54	44	12	2	27	19	30	SD1T 6 G		
8	10	1,5	M 18x1,5	G ¼ A	18	104	54	47,5	12	2	27	22	32	SD1T 8 G		
10	12	1,75	M 20x1,5	G 3/8 A	22	114	60	52	12	2,5	32	24	36	SD1T 10 G		
12	15	2	M 22x1,5	G ½ A	26	120	62	54	14	3	32	27	36	SD1T 12 G		
16	18	2	M 26x1,5	G ½ A	26	128	66	61	14	3	41	32	41	SD1T 16 G		
20	22	2	M 30x1,5	G ¾ A	32	138	70	71	16	3	46	36	46	SD1T 20 G		
25	28	2,5	M 36x2	G 1 A	39	168	94	74	18	3	46	41	50	SD1T 25 G		
32	35	2,5	M 45x2	G 1 ¼ A	49	188	108	78	20	3	55	50	60	SD1T 32 G		
40a	42	3	M 52x2	G 1 ½ A	55	210	124	83	22	3	60	60	65	SD1T 40a G		

SD2T-G Series for pressures up to PN 200:

DN	d ₁	s	d ₃	d ₄	d ₇	L ₃	l ₃	l ₅	i ₂	a ₂	s ₂	s ₃	s ₁₀	Order number	Material number	
															1.0460	1.4571
3	6	1,5	M 14x1,5	G ¼ A	18	98	46	43	12	2	24	19	27	SD2T 3 G		
4	8	2	M 16x1,5	G ¼ A	18	106	54	43	12	2	24	22	27	SD2T 4 G		
6	10	2	M 18x1,5	G 3/8 A	22	106	54	45	12	2,5	27	22	30	SD2T 6 G		
8	12	2	M 20x1,5	G 3/8 A	22	114	58	51	12	2,5	30	24	32	SD2T 8 G		
10	13,5	1,75	M 22x1,5	G ½ A	26	126	62	55	14	3	32	27	36	SD2T 10 G		
12	16	2,5	M 24x1,5	G ½ A	26	130	66	61	14	3	36	30	41	SD2T 12 G		
16	20	2,5	M 30x1,5	G ¾ A	32	142	68	70	16	3	41	36	46	SD2T 16 G		
20	25	2,5	M 36x2	G 1 A	39	180	96	72	18	3	46	46	50	SD2T 20 G		
25	30	3	M 42x2	G 1 ¼ A	49	196	106	80	20	3	50	50	55	SD2T 25 G		
32	38	3,5	M 52x2	G 1 ½ A	55	224	122	86	22	3	60	60	65	SD2T 32 G		

SD3T-G Series for pressures up to PN 320:

DN	d ₁	s	d ₃	d ₄	d ₇	L ₃	l ₃	l ₅	i ₂	a ₂	s ₂	s ₃	s ₁₀	Order number	Material number	
															1.0460	1.4571
3	6	1,5	M 14x1,5	G ¼ A	18	96	46	44	12	2	24	19	27	SD3T 3 G		
4	8	2	M 16x1,5	G ¼ A	18	104	54	44	12	2	24	22	27	SD3T 4 G		
5	10	2,5	M 18x1,5	G 3/8 A	22	104	54	49	12	2,5	27	24	30	SD3T 5 G		
6	12	3	M 20x1,5	G 3/8 A	22	118	60	50	12	2,5	27	27	30	SD3T 6 G		
8	13,5	2,75	M 22x1,5	G ½ A	26	126	64	55	14	3	30	30	36	SD3T 8 G		
10	16	3	M 24x1,5	G ½ A	26	136	66	58	14	3	32	32	36	SD3T 10 G		
12	20	4	M 30x1,5	G ¾ A	32	148	70	69	16	3	36	36	41	SD3T 12 G		
16	25	4,5	M 36x2	G 1 A	39	183	97	72	18	3	46	46	50	SD3T 16 G		
20	30	5	M 42x2	G 1 ¼ A	49	208	112	79	20	3	50	50	55	SD3T 20 G		
25a	35	5,5	M 48x2	G 1 ½ A	55	227	126	87	22	3	60	55	65	SD3T 25a G		
25	38	6	M 52x2	G 1 ½ A	55	234	126	87	22	3	60	60	65	SD3T 25 G		

For orders on individual parts we need the following information:

Pieces	Component	Designation	Order number	Material number
2	1	Weld-on stub	(M-Series)-(DN)- 1	_____
2	2	Clamping nut	(M-Series)-(DN)- 2	_____
1	5	Screw-in stub	(SD-Series)-(DN)- 5	_____
1	75	Tee swivel piece	(SD-Series)-(DN)- 75	_____

Materials: see „Material standards“ page 6

Accessories: copper seals
see page 66



Throttlefree L-swivel unions

with Whitworth thread



- With weld-on end (adjustable)
- Available for tube diameters from DN 3 up to DN 40
- Temperature-resistant from -270 °C up to +500 °C (dependant on the material used)
- Available in DIN EN materials: 1.0460 and 1.4571
Other materials on request.
- Six-part union consisting of 2 weld-on stubs, 2 clamping nuts, 1 screw-in stub and 1 L swivel piece

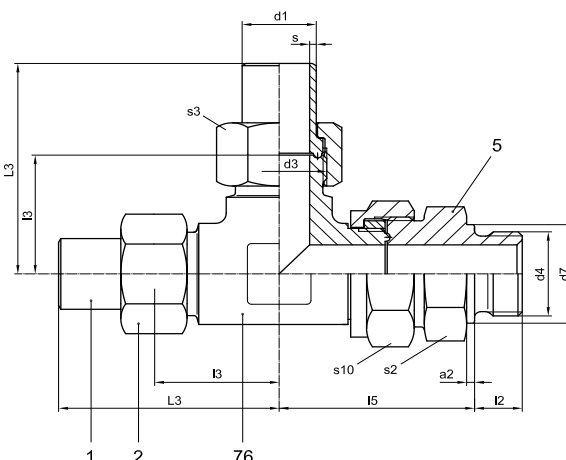

SD1L-G Series for pressures up to PN 100:

DN	d ₁	s	d ₃	d ₄	d ₇	L ₃	l ₃	l ₅	i ₂	a ₂	s ₂	s ₃	s ₁₀	Order number	Material number	
															1.0460	1.4571
4	6	1,25	M 14x1,5	G 1/8 A	14	42	21	42	8	1,5	24	17	27	SD1L 4 G		
6	8	1,5	M 16x1,5	G 1/4 A	18	50	27	44	12	2	27	19	30	SD1L 6 G		
8	10	1,5	M 18x1,5	G 1/4 A	18	52	27	47,5	12	2	27	22	32	SD1L 8 G		
10	12	1,75	M 20x1,5	G 3/8 A	22	57	30	52	12	2,5	32	24	36	SD1L 10 G		
12	15	2	M 22x1,5	G 1/2 A	26	60	31	54	14	3	32	27	36	SD1L 12 G		
16	18	2	M 26x1,5	G 1/2 A	26	64	33	61	14	3	41	32	41	SD1L 16 G		
20	22	2	M 30x1,5	G 3/4 A	32	69	35	71	16	3	46	36	46	SD1L 20 G		
25	28	2,5	M 36x2	G 1 A	39	84	47	74	18	3	46	41	50	SD1L 25 G		
32	35	2,5	M 45x2	G 1 1/4 A	49	94	54	78	20	3	55	50	60	SD1L 32 G		
40a	42	3	M 52x2	G 1 1/2 A	55	105	62	83	22	3	60	60	65	SD1L 40a G		

SD2L-G Series for pressures up to PN 200:

DN	d ₁	s	d ₃	d ₄	d ₇	L ₃	l ₃	l ₅	i ₂	a ₂	s ₂	s ₃	s ₁₀	Order number	Material number	
															1.0460	1.4571
3	6	1,5	M 14x1,5	G ¼ A	18	49	23	43	12	2	24	19	27	SD2L 3 G		
4	8	2	M 16x1,5	G ¼ A	18	53	27	43	12	2	24	22	27	SD2L 4 G		
6	10	2	M 18x1,5	G 3/8 A	22	53	27	45	12	2,5	27	22	30	SD2L 6 G		
8	12	2	M 20x1,5	G 3/8 A	22	57	29	51	12	2,5	30	24	32	SD2L 8 G		
10	13,5	1,75	M 22x1,5	G ½ A	26	63	31	55	14	3	32	27	36	SD2L 10 G		
12	16	2,5	M 24x1,5	G ½ A	26	65	33	61	14	3	36	30	41	SD2L 12 G		
16	20	2,5	M 30x1,5	G ¾ A	32	71	34	70	16	3	41	36	46	SD2L 16 G		
20	25	2,5	M 36x2	G 1 A	39	90	48	72	18	3	46	46	50	SD2L 20 G		
25	30	3	M 42x2	G 1 ¼ A	49	98	53	80	20	3	50	50	55	SD2L 25 G		
32	38	3,5	M 52x2	G 1 ½ A	55	112	61	86	22	3	60	60	65	SD2L 32 G		

SD3L-G Series for pressures up to PN 320:

DN	d ₁	s	d ₃	d ₄	d ₇	L ₃	l ₃	l ₅	i ₂	a ₂	s ₂	s ₃	s ₁₀	Order number	Material number	
															1.0460	1.4571
3	6	1,5	M 14x1,5	G ¼ A	18	48	23	44	12	2	24	19	27	SD3L 3 G		
4	8	2	M 16x1,5	G ¼ A	18	52	27	44	12	2	24	22	27	SD3L 4 G		
5	10	2,5	M 18x1,5	G 3/8 A	22	52	27	49	12	2,5	27	24	30	SD3L 5 G		
6	12	3	M 20x1,5	G 3/8 A	22	59	30	50	12	2,5	27	27	30	SD3L 6 G		
8	13,5	2,75	M 22x1,5	G ½ A	26	63	32	55	14	3	30	30	36	SD3L 8 G		
10	16	3	M 24x1,5	G ½ A	26	68	33	58	14	3	32	32	36	SD3L 10 G		
12	20	4	M 30x1,5	G ¾ A	32	74	35	69	16	3	36	36	41	SD3L 12 G		
16	25	4,5	M 36x2	G 1 A	39	92	49	72	18	3	46	46	50	SD3L 16 G		
20	30	5	M 42x2	G 1 ¼ A	49	104	56	79	20	3	50	50	55	SD3L 20 G		
25a	35	5,5	M 48x2	G 1 ½ A	55	114	63	87	22	3	60	55	65	SD3L 25a G		
25	38	6	M 52x2	G 1 ½ A	55	117	63	87	22	3	60	60	65	SD3L 25 G		

For orders on individual parts we need the following information:

Pieces	Component	Designation	Order number	Material number
2	1	Weld-on stub	(M-Series)-(DN)- 1	_____
2	2	Clamping nut	(M-Series)-(DN)- 2	_____
1	5	Screw-in stub	(SD-Series)-(DN)- 5	_____
1	76	L swivel piece	(SD-Series)-(DN)- 76	_____

Materials: see „Material standards“ page 6

Accessories: copper seals
see page 66



Gauge connecting unions

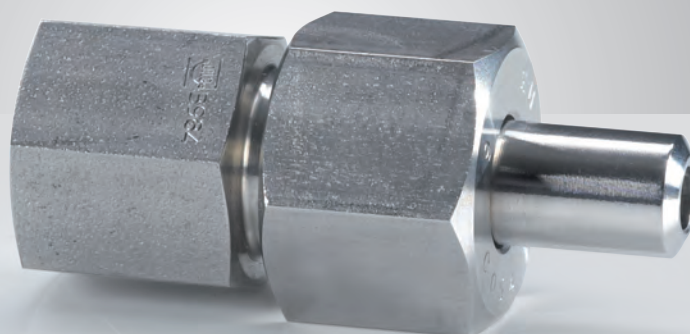

These gauge connecting unions allow comfortable and safe assembly of pressure gauges in pipe systems ranging from DN3 to DN10.

The versions for different pressure ranges and thread types cover all standard requirements.

On request, the suitable copper seals are available as optional accessories.

■ Gauge connecting unions

52

Gauge connecting unions

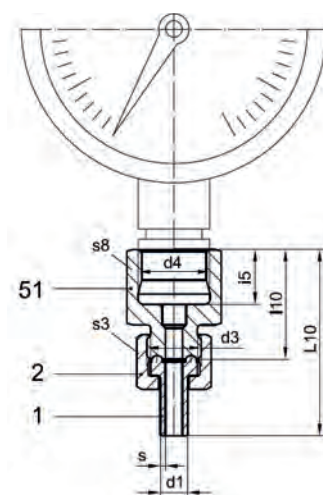
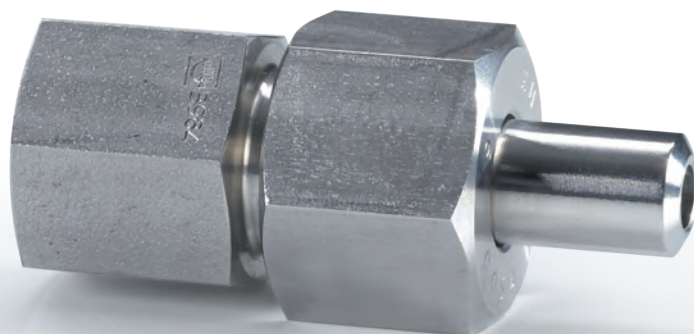

- For reliable connection of gauges
- Available in pressure ranges of PN 100, 200 and 320 bar
- Suitable for G ¼", G ½" gauge threads and all commercial types
- Available in DN 3 to DN 10 tube diameters
- Other thread diameters are available on request
- Available in DIN EN materials: 1.0460 and 1.4571
Other materials on request.

M1M-G Series for pressures up to PN 100:

M1M-G series for G ¼ gauge thread

DN	d ₁	s	d ₃	d ₄	L ₁₀	l ₁₀	i ₅	s ₃	s ₈	Order number	Material number	
											1.0460	1.4571
8	10	1,5	M 18x1,5	G ¼"	54	29	13	22	19	M1M 8 / 59		
10	12	1,75	M 20x1,5	G ¼"	56	29	13	24	24	M1M 10 / 59		

Accessories: copper seals for G ¼ gauge thread
see page 67



M1M-G series for G ½ gauge thread

DN	d ₁	s	d ₃	d ₄	L ₁₀	l ₁₀	i ₅	s ₃	s ₈	Order number	Material number	
											1.0460	1.4571
4	6	1,25	M 14x1,5	G ½"	53	32	16	17	24	M1M 4 / 51		
6	8	1,5	M 16x1,5	G ½"	55	32	16	19	24	M1M 6 / 51		
8	10	1,5	M 18x1,5	G ½"	59	34	16	22	24	M1M 8 / 51		
10	12	1,75	M 20x1,5	G ½"	61	34	16	24	24	M1M 10 / 51		

Accessories: copper seals for G ½ gauge thread
see page 68



Gauge connecting unions

M2M-G Series for pressures up to PN 200:

DN	d ₁	s	d ₃	d ₄	L ₁₀	l ₁₀	i ₅	s ₃	s ₈	Order number	Material number	
											1.0460	1.4571
3	6	1,5	M 14x1,5	G ½	57	32	16	19	27	M2M 3 / 51		
4	8	2	M 16x1,5	G ½	57	32	16	22	27	M2M 4 / 51		
6	10	2	M 18x1,5	G ½	57	32	16	22	27	M2M 6 / 51		
8	12	2	M 20x1,5	G ½	61	34	16	24	27	M2M 8 / 51		
10	13,5	1,75	M 22x1,5	G ½	65	34	16	27	27	M2M 10 / 51		

Accessories: copper seals for G ½ gauge thread
see page 68



M3M-G Series for pressures up to PN 320:

DN	d ₁	s	d ₃	d ₄	L ₁₀	l ₁₀	i ₅	s ₃	s ₈	Order number	Material number	
											1.0460	1.4571
3	6	1,5	M 14x1,5	G ½	57	32	16	19	27	M3M 3 / 51		
4	8	2	M 16x1,5	G ½	57	32	16	22	27	M3M 4 / 51		
5	10	2,5	M 18x1,5	G ½	57	32	16	24	30	M3M 5 / 51		
6	12	3	M 20x1,5	G ½	64	35	16	27	30	M3M 6 / 51		
8	13,5	2,75	M 22x1,5	G ½	66	35	16	30	30	M3M 8 / 51		
10	16	3	M 24x1,5	G ½	73	38	16	32	30	M3M 10 / 51		

Accessories: copper seals for G ½ gauge thread
see page 68



For orders on individual parts we need the following information:

Pieces	Component	Designation	Order number	Material number
1	1	Weld-on stub	(Series)-(DN)- 1	_____
1	2	Clamping nut	(Series)-(DN)- 2	_____
1	51	Gauge connection piece	(Series)-(DN)- 51	_____

Material:

Material number acc. to DIN	Material specification	AISI material specification	DILO material code letter
1.0460	P250GH	1022M	A
1.4571	X6CrNiMoTi17-12-2	316 Ti	C
1.7335	13CrMo4-5	A 182	D

 Parts available from stock

Superheated steam unions



Where high temperatures have to be withstood DILO superheated steam unions demonstrate its greatest strength. They are available as weld-on or screw-in version, including different thread types withstanding pressures up to PN 100.

■ Superheated steam unions

- Superheated steam weld-on unions 52
- Superheated steam screw-in unions with metric thread 54
- Superheated steam screw-in unions with Whitworth thread 56
- Blanking disks 58

Superheated steam weld-on unions

up to 500 °C operating temperature



- With weld-on ends
- Available for pressures up to PN 100
- Available for tube diameters from DN 3 up to DN 40
- High temperature-resistant 1.7335 steel
- Special materials for higher temperatures on request
- Three-part union consisting of weld-on stub, clamping nut and weld-on screw stub

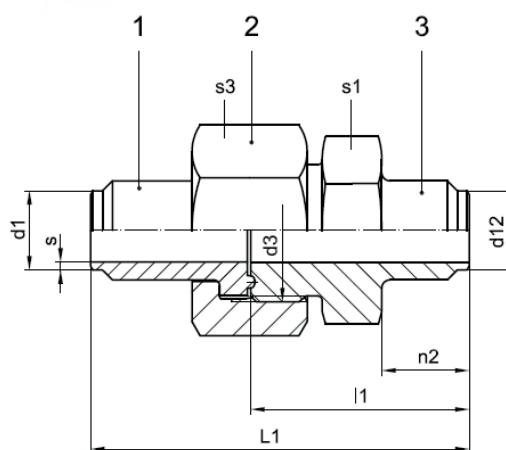

MH1A Series for pressures up to PN 100:

DN	d ₁	s	d ₃	d ₁₂	L ₁	l ₁	n ₂	s ₁	s ₃	Order number	Material number 1.7335
3	6	1,5	M 16x1,5	6	53	28	10	17	22	MH1A 3	
4	8	2	M 18x1,5	8	58	33	14	19	22	MH1A 4	
6	10	2	M 20x1,5	10	64	37	17	22	24	MH1A 6	
8	12	2	M 22x1,5	12	71	40	17	24	27	MH1A 8	
10	13,5	1,75	M 24x1,5	13,5	75	44	20	27	30	MH1A 10	
12	16	2	M 30x2	16	84	48	20	32	36	MH1A 12	
16	20	2	M 36x2	20	96	55	22	41	46	MH1A 16	
20	25	2,5	M 42x2	25	106	62	26	46	50	MH1A 20	
25	30	3	M 52x2	30	118	68	28	55	60	MH1A 25	
32	38	3,5	M 56x2	38	129	74	31	60	65	MH1A 32	
40	44	4,25	M 68x2	44	139	80	34	70	80	MH1A 40	

JH1A Series for pressures up to PN 100:

DN	d ₁	s	d ₃	d ₁₂	L ₁	l ₁	n ₂	s ₁	s ₃	Order number	Material number 1.7335
3	6	1,5	M 16x1,5	6	53	28	10	17	22	JH1A 3	
4	8	2	M 18x1,5	8	58	33	14	19	22	JH1A 4	
6	10	2	M 20x1,5	10	64	37	17	22	24	JH1A 6	
8	12	2	M 22x1,5	12	71	40	17	24	27	JH1A 8	
10	13,5	1,75	M 24x1,5	13,5	75	44	20	27	30	JH1A 10	
12	17	2,5	M 30x2	17	83	47	20	32	36	JH1A 12	
16	21	2,5	M 36x2	21	96	55	22	41	46	JH1A 16	
20	27	3	M 42x2	27	106	62	26	46	50	JH1A 20	
25	34	4	M 52x2	34	118	68	28	55	60	JH1A 25	
32	42	3,5	M 56x2	42	129	74	31	60	65	JH1A 32	
40	48	4	M 68x2	48	141	81	34	70	80	JH1A 40	

For orders on individual parts we need the following information:

Pieces	Component	Designation	Order number	Material number
1	1	Weld-on stub	(Series)-(DN)- 1	_____
1	2	Clamping nut	(Series)-(DN)- 2	_____
1	3	Weld-on screw stub	(Series)-(DN)- 3	_____

Material:

Material number acc. to DIN	Material specification	AISI material specification	DILO material code letter
1.7335	13CrMo4-5	A 182	D

Superheated steam screw-in unions

up to 500 °C operating temperature with metric thread



- With weld-on end and screw-in thread
- Available for pressures up to PN 100
- Available for tube diameters from DN 3 up to DN 40
- High temperature-resistant 1.7335 steel
- Special materials for higher temperatures on request
- Three-part union consisting of weld-on stub, clamping nut and screw-in stub

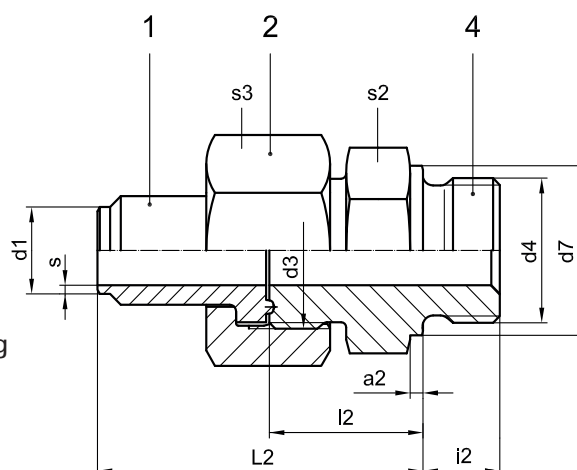

MH1B Series for pressures up to PN 100:

DN	d ₁	s	d ₃	d ₄	d ₇	L ₂	l ₂	i ₂	a ₂	s ₂	s ₃	Order number	Material number 1.7335
3	6	1,5	M 16x1,5	M 14x1,5	19	46	21	12	2	19	22	MH1B 3	
4	8	2	M 18x1,5	M 16x1,5	21	47	22	12	2	22	22	MH1B 4	
6	10	2	M 20x1,5	M 18x1,5	23	51	24	12	2,5	24	24	MH1B 6	
8	12	2	M 22x1,5	M 20x1,5	25	58	27	14	2,5	27	27	MH1B 8	
10	13,5	1,75	M 24x1,5	M 22x1,5	27	58	27	14	3	27	30	MH1B 10	
12	16	2	M 30x2	M 27x2	32	67	31	16	3	32	36	MH1B 12	
16	20	2	M 36x2	M 33x2	39	77	36	18	3	41	46	MH1B 16	
20	25	2,5	M 42x2	M 42x2	49	84	40	20	3	50	50	MH1B 20	
25	30	3	M 52x2	M 48x2	55	93	43	22	3	55	60	MH1B 25	
32	38	3,5	M 56x2	M 56x2	64	103	48	24	3,5	65	65	MH1B 32	
40	44	4,25	M 68x2	M 60x2	68	109	50	24	3,5	70	80	MH1B 40	

JH1B Series for pressures up to PN 100:

DN	d ₁	s	d ₃	d ₄	d ₇	L ₂	l ₂	i ₂	a ₂	s ₂	s ₃	Order number	Material number 1.7335
3	6	1,5	M 16x1,5	M 14x1,5	19	46	21	12	2	19	22	JH1B 3	
4	8	2	M 18x1,5	M 16x1,5	21	47	22	12	2	22	22	JH1B 4	
6	10	2	M 20x1,5	M 18x1,5	23	51	24	12	2,5	24	24	JH1B 6	
8	12	2	M 22x1,5	M 20x1,5	25	58	27	14	2,5	27	27	JH1B 8	
10	13,5	1,75	M 24x1,5	M 22x1,5	27	58	27	14	3	27	30	JH1B 10	
12	17	2,5	M 30x2	M 27x2	32	67	31	16	3	32	36	JH1B 12	
16	21	2,5	M 36x2	M 33x2	39	77	36	18	3	41	46	JH1B 16	
20	27	3	M 42x2	M 42x2	49	84	40	20	3	50	50	JH1B 20	
25	34	4	M 52x2	M 48x2	55	93	43	22	3	55	60	JH1B 25	
32	42	3,5	M 56x2	M 56x2	64	103	48	24	3,5	65	65	JH1B 32	
40	48	4	M 68x2	M 60x2	68	110	50	24	3,5	70	80	JH1B 40	

For orders on individual parts we need the following information:

Pieces	Component	Designation	Order number	Material number
1	1	Weld-on stub	(Series)-(DN)- 1	_____
1	2	Clamping nut	(Series)-(DN)- 2	_____
1	4	Screw-in stub	(Series)-(DN)- 4	_____

Material:

Material number acc. to DIN	Material specification	AISI material specification	DILO material code letter
1.7335	13CrMo4-5	A 182	D

Superheated steam screw-in unions

up to 500 °C operating temperature with Whitworth thread



- With weld-on end and screw-in thread
- Available for pressures up to PN 100
- Available for tube diameters from DN 3 up to DN 40
- High temperature-resistant 1.7335 steel
- Special materials for higher temperatures on request
- Three-part union consisting of weld-on stub, clamping nut and screw-in stub

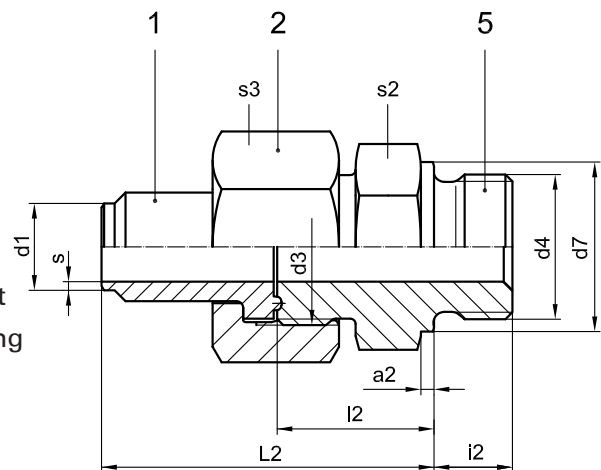

MH1B-G Series for pressures up to PN 100:

DN	d ₁	s	d ₃	d ₄	d ₇	L ₂	l ₂	i ₂	a ₂	s ₂	s ₃	Order number	Material number 1.7335
3	6	1,5	M 16x1,5	G ¼ A	18	46	21	12	2	19	22	MH1B 3 G	
4	8	2	M 18x1,5	G 3/8 A	22	48	23	12	2,5	22	22	MH1B 4 G	
6	10	2	M 20x1,5	G 3/8 A	22	51	24	12	2,5	24	24	MH1B 6 G	
8	12	2	M 22x1,5	G ½ A	26	58	27	14	3	27	27	MH1B 8 G	
10	13,5	1,75	M 24x1,5	G ½ A	26	58	27	14	3	27	30	MH1B 10 G	
12	16	2	M 30x2	G ¾ A	32	67	31	16	3	32	36	MH1B 12 G	
16	20	2	M 36x2	G 1 A	39	77	36	18	3	41	46	MH1B 16 G	
20	25	2,5	M 42x2	G 1 ¼ A	49	84	40	20	3	50	50	MH1B 20 G	
25	30	3	M 52x2	G 1 ½ A	55	93	43	22	3	55	60	MH1B 25 G	
32	38	3,5	M 56x2	G 1 ¾ A	62	103	48	24	3,5	65	65	MH1B 32 G	
40	44	4,25	M 68x2	G 2 A	68	109	50	24	3,5	70	80	MH1B 40 G	

JH1B-G Series for pressures up to PN 100:

DN	d ₁	s	d ₃	d ₄	d ₇	L ₂	l ₂	i ₂	a ₂	s ₂	s ₃	Order number	Material number 1.7335
3	6	1,5	M 16x1,5	G ¼ A	18	46	21	12	2	19	22	JH1B 3 G	
4	8	2	M 18x1,5	G 3/8 A	22	48	23	12	2	22	22	JH1B 4 G	
6	10	2	M 20x1,5	G 3/8 A	22	51	24	12	2,5	24	24	JH1B 6 G	
8	12	2	M 22x1,5	G ½ A	26	58	27	14	2,5	27	27	JH1B 8 G	
10	13,5	1,75	M 24x1,5	G ½ A	26	58	27	14	3	27	30	JH1B 10 G	
12	17	2,5	M 30x2	G ¾ A	32	67	31	16	3	32	36	JH1B 12 G	
16	21	2,5	M 36x2	G 1 A	39	77	36	18	3	41	46	JH1B 16 G	
20	27	3	M 42x2	G 1 ¼ A	49	84	40	20	3	50	50	JH1B 20 G	
25	34	4	M 52x2	G 1 ½ A	55	93	43	22	3	55	60	JH1B 25 G	
32	42	3,5	M 56x2	G 1 ¾ A	62	103	48	24	3,5	65	65	JH1B 32 G	
40	48	4	M 68x2	G 2 A	68	110	50	24	3,5	70	80	JH1B 40 G	

For orders on individual parts we need the following information:

Pieces	Component	Designation	Order number	Material number
1	1	Weld-on stub	(Series)-(DN)- 1	_____
1	2	Clamping nut	(Series)-(DN)- 2	_____
1	5	Screw-in stub	(Series)-(DN)- 5	_____

Material:

Material number acc. to DIN	Material specification	AISI material specification	DILO material code letter
1.7335	13CrMo4-5	A 182	D

Blanking disks

up to 500 °C operating temperature



- For assembly between tongue and groove part
- Available for tube diameters from DN 3 up to DN 40

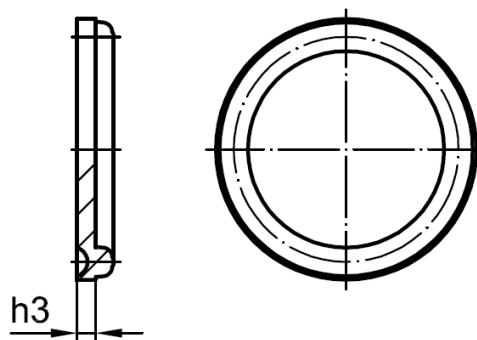

MH1 Series Component 8 for pressures up to PN 100:

DN	h_3	Order number	Material number 1.4922
3	1,5	MH1-3-8	
4	1,5	MH1-4-8	
6	2	MH1-6-8	
8	2	MH1-8-8	
10	2	MH1-10-8	
12	2	MH1-12-8	
16	2,5	MH1-16-8	
20	3	MH1-20-8	
25	3,5	MH1-25-8	
32	3,9	MH1-32-8	
40	4,7	MH1-40-8	

JH1 Series Component 8 for pressures up to PN 100:

DN	h_3	Order number	Material number 1.4922
3	1,5	JH1-3-8	
4	1,5	JH1-4-8	
6	2	JH1-6-8	
8	2	JH1-8-8	
10	2	JH1-10-8	
12	2	JH1-12-8	
16	2,5	JH1-16-8	
20	3	JH1-20-8	
25	3,5	JH1-25-8	
32	3,9	JH1-32-8	
40	4,7	JH1-40-8	

Material:

Material number acc. to DIN	Material specification	AISI material specification	DILO material code letter
1.4922	X20CrMoV11-1	---	Q

Blanking disks with boring

up to 500 °C operating temperature

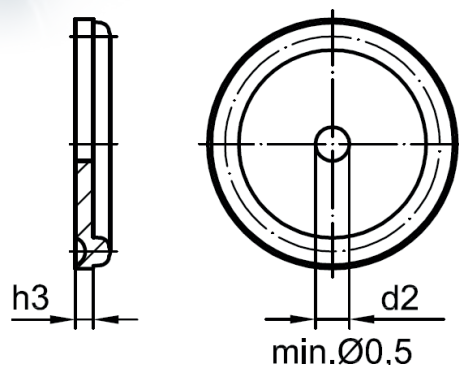

- For assembly between tongue and groove part
- Available for tube diameters from DN 3 up to DN 40
- Version with throttle boring for flow reduction

Please indicate the required boring diameter!

MH1 Series Component 8 for pressures up to PN 100:

DN	h ₃	d ₂	Order number
3	1,5	_____	MH1-3-8-N1
4	1,5	_____	MH1-4-8-N1
6	2	_____	MH1-6-8-N1
8	2	_____	MH1-8-8-N1
10	2	_____	MH1-10-8-N1
12	2	_____	MH1-12-8-N1
16	2,5	_____	MH1-16-8-N1
20	3	_____	MH1-20-8-N1
25	3,5	_____	MH1-25-8-N1
32	3,9	_____	MH1-32-8-N1
40	4,7	_____	MH1-40-8-N1

JH1 Series Component 8 for pressures up to PN 100:

DN	h ₃	d ₂	Order number
3	1,5	_____	JH1-3-8-N1
4	1,5	_____	JH1-4-8-N1
6	2	_____	JH1-6-8-N1
8	2	_____	JH1-8-8-N1
10	2	_____	JH1-10-8-N1
12	2	_____	JH1-12-8-N1
16	2,5	_____	JH1-16-8-N1
20	3	_____	JH1-20-8-N1
25	3,5	_____	JH1-25-8-N1
32	3,9	_____	JH1-32-8-N1
40	4,7	_____	JH1-40-8-N1

Material:

Material number acc. to DIN	Material specification	AISI material specification	DILO material code letter
1.4922	X20CrMoV11-1	---	Q



For mounting of the DILO screw-in unions we recommend using copper seals for sealing of the screw-in plug according to DIN 3852-1 and DIN EN ISO 1179 opposite the housing or the block.

Furthermore we recommend copper seals for axial sealing of gauge connecting unions.

■ Copper seals

66

Flat seal rings

according to DIN 7603 form A



- For Whitworth G 1/8 A to G 2 A pipe thread diameters
- Suitable to seal screw in tube unions with Whitworth thread
- Material: copper
- Temperature resistant up to 300 °C

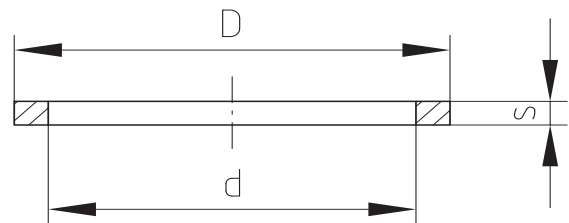

Nominal width	for thread	d	D	s	Order number
10x16	G 1/8 A	10,2	15,9	1,0	05-0568-R012
13,5x18	G 1/4 A	13,7	17,9	2,0	05-0568-R006
17x22	G 3/8 A	17,2	21,9	2,0	05-0568-R009
21x26	G 1/2 A	21,2	25,9	1,5	05-0568-R015
27x32	G 3/4 A	27,3	31,9	2,0	05-0568-R016
35x41	G 1 A	35,3	40,9	2,0	05-0568-R022
42x49	G 1 1/4 A	42,3	48,9	2,0	05-0568-R023
48x55	G 1 1/2 A	48,3	54,9	2,0	05-0568-R024
54x62	G 1 3/4 A	54,5	61,8	2,5	05-0568-R025
60x68	G 2 A	60,5	67,8	2,5	05-0568-R026

Profiled seal ring

for gauge connecting union



- For internal centering by gauge pin
- Material: copper
- Temperature resistant up to 300 °C

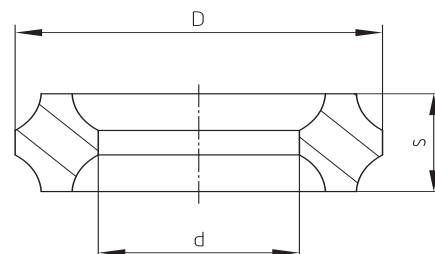

Thread type

Pipe thread	Metric thread	d	D	s	Order number
G 1/8	---	4	8	2,7	05-0078-R001
G 1/4	M 12x1,5	5,4	9,3	3,2	05-0078-R002
G 1/2	M 20x1,5	8	15,2	4,2	05-0078-R003

Convex seal rings

for gauge connecting union according to DIN 7603 form D



- To seal gauge connecting unions with thread G 1/2
- Material: copper
- Temperature resistant up to 300 °C

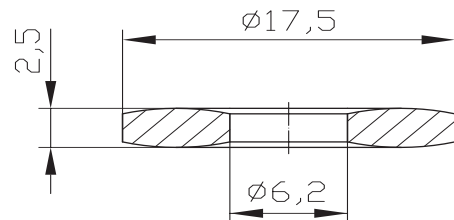

Order number: 05-0091-R001

Valves

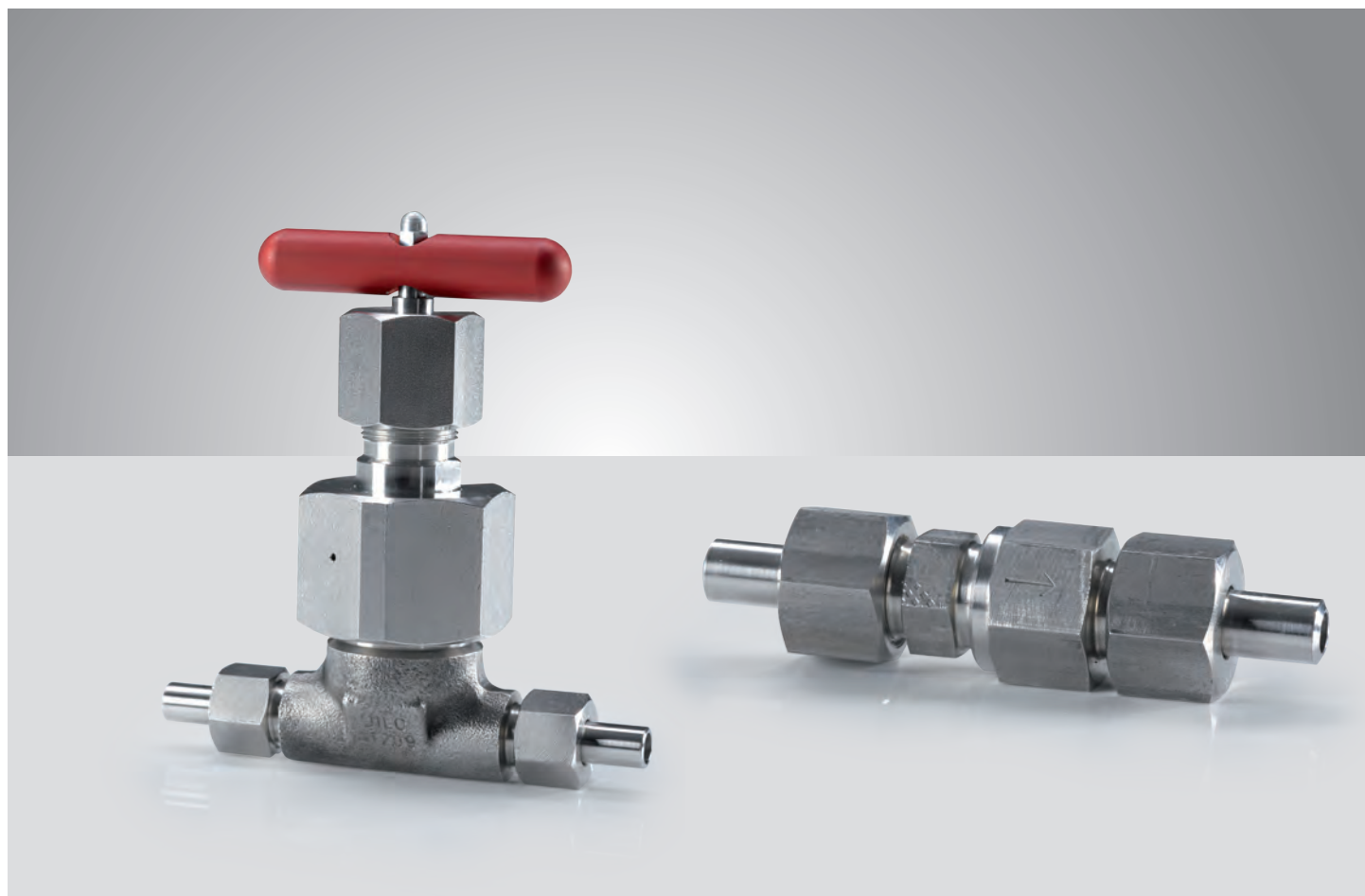

Durable and robust version for regulating the media flow. Liquids and gases are handled safely and reliably.

DILO valves are available with weld-on ends. The suitable DILO connecting parts are included in the scope of supply.

■ Valves

- Manual blocking valves 62
- Non-return valves 64

Manual blocking valves

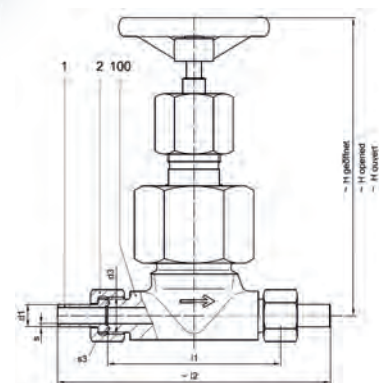

- Delivery complete with DILO connecting parts
- Range of application from -270 °C up to +400 °C
- Available in DIN EN materials 1.0460 and 1.4571

M1HAV Series for pressures up to PN 100:

DN	d ₁	s	d ₃	l ₁	~l ₂	s ₃	~H	Order number
6	8	1,5	M 16x1,5	92	137	19	158	M1-HAV-6
10	12	1,75	M 20x1,5	92	145	24	158	M1-HAV-10
16	18	2	M 26x1,5	130	191	32	216	M1-HAV-16
20	22	2	M 30x1,5	130	197	36	216	M1-HAV-20
25	28	2,5	M 36x2	180	253	41	234	M1-HAV-25
32	35	2,5	M 45x2	180	259	50	234	M1-HAV-32

J1HAV Series for pressures up to PN 100:

DN	d ₁	s	d ₃	l ₁	~l ₂	s ₃	~H	Order number
6	8	1,5	M 16x1,5	92	137	19	158	J1-HAV-6
10	13,5	1,75	M 22x1,5	92	154	27	158	J1-HAV-10
16	21	2,5	M 30x2	130	202	36	216	J1-HAV-16
20	27	3	M 36x2	130	204	41	216	J1-HAV-20
25	34	3,5	M 45x2	180	260	50	234	J1-HAV-25
32	42	3,5	M 52x2	180	268	60	234	J1-HAV-32

M2HAV Series for pressures up to PN 200:

DN	d ₁	s	d ₃	l ₁	~l ₂	s ₃	~H	Order number
3	6	1,5	M 14x1,5	92	141	19	158	M2-HAV-3
6	10	2	M 18x1,5	92	141	22	158	M2-HAV-6
10	13,5	1,75	M 22x1,5	92	153	27	158	M2-HAV-10
16	20	2,5	M 30x2	130	201	36	216	M2-HAV-16

J2HAV Series for pressures up to PN 250:

DN	d ₁	s	d ₃	l ₁	~l ₂	s ₃	~H	Order number
3	6	1,5	M 14x1,5	92	141	19	158	J2-HAV-3
6	10	2	M 18x1,5	92	141	22	158	J2-HAV-6
10	13,5	1,75	M 22x1,5	92	153	27	158	J2-HAV-10
16	21	2,5	M 30x2	130	202	36	216	J2-HAV-16

M3HAV Series for pressures up to PN 320:

DN	d ₁	s	d ₃	l ₁	~l ₂	s ₃	~H	Order number
3	6	1,5	M 14x1,5	92	141	19	158	M3-HAV-3
6	12	3	M 20x1,5	92	149	27	158	M3-HAV-6
10	16	3	M 24x1,5	92	161	32	158	M3-HAV-10
16	25	4,5	M 36x2	130	215	46	234	M3-HAV-16

J3HAV Series for pressures up to PN 320:

DN	d ₁	s	d ₃	l ₁	~l ₂	s ₃	~H	Order number
3	6	1,5	M 14x1,5	92	141	19	158	J3-HAV-3
6	12	3	M 20x1,5	92	149	27	158	J3-HAV-6
10	17	3	M 27x2	130	200	36	216	J3-HAV-10
16	27	4,5	M 39x2	130	216	46	216	J3-HAV-16

For orders on individual parts we need the following information:

Pieces	Component	Designation	Order number	Material number
2	1	Weld-on stub	(Series)-(DN)- 1	_____
2	2	Clamping nut	(Series)-(DN)- 2	_____
1	100	Manual blocking valve	(Series)-(DN)- 100	_____

Material:

Material number acc. to DIN	Material specification	AISI material specification	DILO material code letter
1.0460	P250GH	1022M	A
1.4571	X6CrNiMoTi17-12-2	316Ti	C

Non-return valves

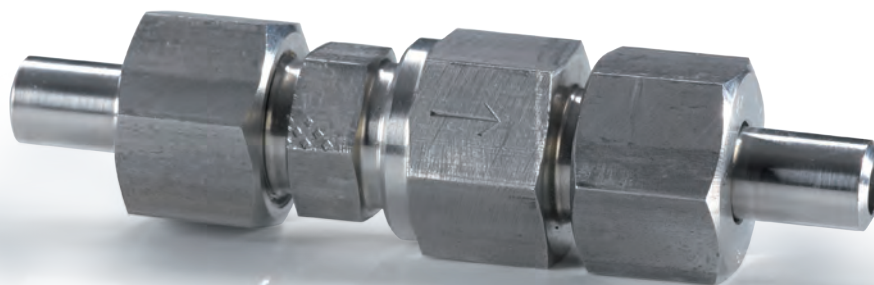

- Delivery complete with DILO connecting parts
- Temperature range: -20 °C to +70 °C (media-dependent)
- Response pressure: about 1 bar
- Rubber seal: Perbunan
- Available in DIN EN materials 1.0460 and 1.4571

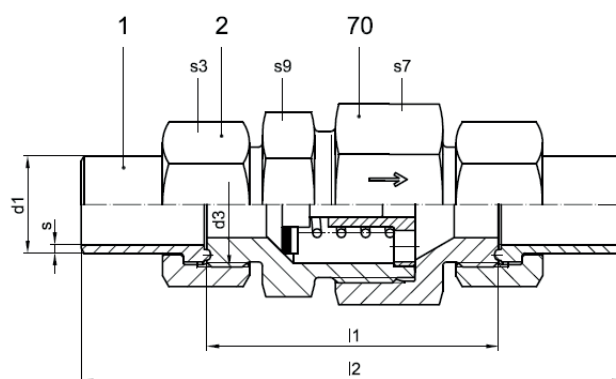

M1RV Series for pressures up to PN 100:

DN	d ₁	s	d ₃	l ₁	l ₂	s ₃	s ₇	s ₉	Order number
4	6	1,25	M 14x1,5	57	98	17	27	24	M1-RV-4
6	8	1,5	M 16x1,5	57	102	19	27	24	M1-RV-6
8	10	1,5	M 18x1,5	61	110	22	27	24	M1-RV-8
10	12	1,75	M 20x1,5	61	114	24	27	24	M1-RV-10
12	15	2	M 22x1,5	64	121	27	30	27	M1-RV-12
16	18	2	M 26x1,5	65	126	32	36	30	M1-RV-16
20	22	2	M 30x1,5	76	143	36	46	41	M1-RV-20
25	28	2,5	M 36x2	84	157	41	50	46	M1-RV-25
32	35	2,5	M 45x2	91	170	50	60	55	M1-RV-32

J1RV Series for pressures up to PN 100:

DN	d ₁	s	d ₃	l ₁	l ₂	s ₃	s ₇	s ₉	Order number
4	6	1,25	M 14x1,5	57	98	17	27	24	J1-RV-4
6	8	1,5	M 16x1,5	57	102	19	27	24	J1-RV-6
8	10	1,5	M 18x1,5	61	110	22	27	24	J1-RV-8
10	13,5	1,75	M 22x1,5	68	130	27	30	24	J1-RV-10
12	17	2,5	M 24x1,5	68	130	30	30	24	J1-RV-12
16	21	2,5	M 30x2	80	152	36	41	36	J1-RV-16
20	27	3	M 36x2	80	154	41	46	41	J1-RV-20
25	34	3,5	M 45x2	91	171	50	60	55	J1-RV-25

M2RV Series for pressures up to PN 200:

DN	d ₁	s	d ₃	l ₁	l ₂	s ₃	s ₇	s ₉	Order number
3	6	1,5	M 14x1,5	61	110	19	27	24	M2-RV-3
4	8	2	M 16x1,5	61	110	22	27	24	M2-RV-4
6	10	2	M 18x1,5	61	110	22	27	24	M2-RV-6
8	12	2	M 20x1,5	61	114	24	27	24	M2-RV-8
10	13,5	1,75	M 22x1,5	68	129	27	30	27	M2-RV-10
12	16	2,5	M 24x1,5	68	129	30	30	27	M2-RV-12
16	20	2,5	M 30x2	80	151	36	41	36	M2-RV-16
20	25	2,5	M 36x2	84	165	46	46	41	M2-RV-20
25	30	3	M 42x2	98	185	50	55	50	M2-RV-25

J2RV Series for pressures up to PN 250:

DN	d ₁	s	d ₃	l ₁	l ₂	s ₃	s ₇	s ₉	Order number
3	6	1,5	M 14x1,5	61	110	19	27	24	J2-RV-3
4	8	2	M 16x1,5	61	110	22	27	24	J2-RV-4
6	10	2	M 18x1,5	61	110	22	27	24	J2-RV-6
8	12	2	M 20x1,5	61	114	24	27	24	J2-RV-8
10	13,5	1,75	M 22x1,5	68	129	27	30	24	J2-RV-10
12	17	2,5	M 24x1,5	68	130	30	30	24	J2-RV-12
16	21	2,5	M 30x1,5	80	152	36	41	36	J2-RV-16
20	27	3,5	M 36x2	84	166	46	46	41	J2-RV-20
25	34	4,5	M 45x2	99	187	55	60	55	J2-RV-25

Non-return valves

M3RV Series for pressures up to PN 320:

DN	d ₁	s	d ₃	l ₁	l ₂	s ₃	s ₇	s ₉	Order number
3	6	1,5	M 14x1,5	61	110	19	27	24	M3-RV-3
4	8	2	M 16x1,5	61	110	22	27	24	M3-RV-4
5	10	2,5	M 18x1,5	61	110	24	27	24	M3-RV-5
6	12	3	M 20x1,5	61	118	27	27	24	M3-RV-6
8	13,5	2,75	M 22x1,5	68	129	30	30	27	M3-RV-8
10	16	3	M 24x1,5	68	137	32	30	27	M3-RV-10
12	20	4	M 30x2	84	163	36	41	36	M3-RV-12
16	25	4,5	M 36x2	88	173	46	46	41	M3-RV-16
20	30	5	M 42x2	102	197	50	55	50	M3-RV-20
25a	35	5,5	M 48x2	107	207	55	60	55	M3-RV-25a
25	38	6	M 52x2	107	213	60	60	55	M3-RV-25

J3RV Series for pressures up to PN 320:

DN	d ₁	s	d ₃	l ₁	l ₂	s ₃	s ₇	s ₉	Order number
3	6	1,5	M 14x1,5	61	110	19	27	24	J3-RV-3
4	8	2	M 16x1,5	61	110	22	27	24	J3-RV-4
5	10	2,5	M 18x1,5	61	110	24	27	24	J3-RV-5
6	12	3	M 20x1,5	61	118	27	27	24	J3-RV-6
8	13,5	2,75	M 22x1,5	68	129	30	30	27	J3-RV-8
10	17	3	M 27x2	75	145	36	36	30	J3-RV-10
12	21	4	M 33x2	86	166	41	46	41	J3-RV-12
16	27	4,5	M 39x2	97	183	46	50	46	J3-RV-16
20	34	5,5	M 48x2	107	205	55	60	55	J3-RV-20

For orders on individual parts we need the following information:

Pieces	Component	Designation	Order number	Material number
2	1	Weld-on stub	(Series)-(DN)- 1	_____
2	2	Clamping nut	(Series)-(DN)- 2	_____
1	70	Non-return valve	(Series)-(DN)- 70	_____

Material:

Material number acc. to DIN	Material specification	AISI material specification	DILO material code letter
1.0460	P250GH	1022M	A
1.4571	X6CrNiMoTi17-12-2	316Ti	C

Blanking disks



We offer blanking disks for closing tubes suitable for any types or series and pressure ranges. On request, they are also available with throttle boring for flow regulation.

<ul style="list-style-type: none"> ■ Blanking disks ■ Blanking disks ■ Blanking disks with boring 	<p>70</p> <p>72</p>
---	---------------------

Blanking disks

- For assembly between tongue and groove part
- For all types and pressure ranges
- Range of application from -270 °C up to +500 °C dependent on the material used

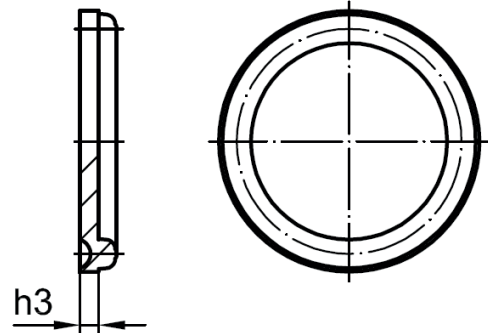

M1 Series Component 8 for pressures up to PN 100:

DN	h ₃	Order number	Material number	
			1.4571	1.4922
4	1,5	M1-4-8		
6	1,5	M1-6-8		
8	1,5	M1-8-8		
10	1,5	M1-10-8		
12	1,5	M1-12-8		
16	1,5	M1-16-8		
20	2,0	M1-20-8		
25	2,0	M1-25-8		
32	2,2	M1-32-8		
40a	2,8	M1-40a-8		
40	3,0	M1-40-8		
50	3,5	M1-50-8		

J1 Series Component 8 for pressures up to PN 100:

DN	h ₃	Order number	Material number	
			1.4571	1.4922
4	1,5	J1-4-8		
6	1,5	J1-6-8		
8	1,5	J1-8-8		
10	2	J1-10-8		
12	2	J1-12-8		
16	2	J1-16-8		
20	2	J1-20-8		
25	2,2	J1-25-8		
32	3,5	J1-32-8		
40	3,5	J1-40-8		
50	3,5	J1-50-8		

M2 Series Component 8 for pressures up to PN 200:

DN	h ₃	Order number	Material number	
			1.4571	1.4922
3	1,5	M2-3-8		
4	1,5	M2-4-8		
6	1,5	M2-6-8		
8	2	M2-8-8		
10	2	M2-10-8		
12	2	M2-12-8		
16	2	M2-16-8		
20	2,5	M2-20-8		
25	3	M2-25-8		
32	3,5	M2-32-8		
40	3,9	M2-40-8		
50	4,7	M2-50-8		

J2 Series Component 8 for pressures up to PN 250:

DN	h ₃	Order number	Material number	
			1.4571	1.4922
3	1,5	J2-3-8		
4	1,5	J2-4-8		
6	1,5	J2-6-8		
8	2	J2-8-8		
10	2	J2-10-8		
12	2	J2-12-8		
16	2	J2-16-8		
20	2,5	J2-20-8		
25	3	J2-25-8		
32	3,5	J2-32-8		
40	5	J2-40-8		

M3 Series Component 8 for pressures up to PN 320:

DN	h ₃	Order number	Material number	
			1.4571	1.4922
3	1,5	M3-3-8		
4	1,5	M3-4-8		
5	2	M3-5-8		
6	2,5	M3-6-8		
8	2,5	M3-8-8		
10	3	M3-10-8		
12	3	M3-12-8		
16	3,5	M3-16-8		
20	4	M3-20-8		
25a	4,5	M3-25a-8		
25	4,5	M3-25-8		
32	5	M3-32-8		

J3 Series Component 8 for pressures up to PN 320:

DN	h ₃	Order number	Material number	
			1.4571	1.4922
3	1,5	J3-3-8		
4	1,5	J3-4-8		
5	2	J3-5-8		
6	2,5	J3-6-8		
8	2,5	J3-8-8		
10	3	J3-10-8		
12	3	J3-12-8		
16	3,5	J3-16-8		
20	4	J3-20-8		
25	4,5	J3-25-8		
32	5	J3-32-8		

Material:

Material number acc. to DIN	Material specification	AISI material specification	DILO material code letter
1.4571	X6CrNiMoTi17-12-2	316Ti	C
1.4922	X20CrMoV11-1	---	Q

Correct mounting of a blanking disk

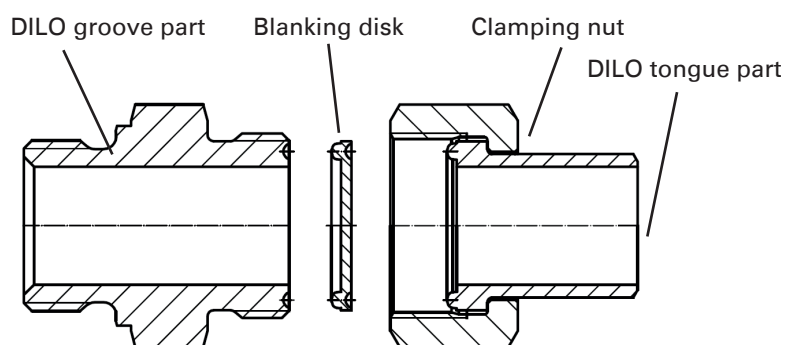

The blanking disk must be fitted in between the groove and tongue. The blanking disk is fixed by pressing the weld-on stub and the clamping nut.

Blanking disks with boring

- For assembly between tongue and groove part
- Version with throttle boring for flow reduction
- For all types and pressure ranges
- Range of application from -270 °C up to +500 °C dependent on the material used

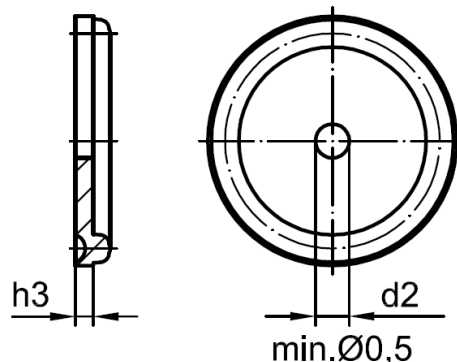

Please indicate the required boring diameter!

M1 Series Component 8 for pressures up to PN 100:

DN	h_3	d_2	Order number
4	1,5	_____	M1-4-8-N1
6	1,5	_____	M1-6-8-N1
8	1,5	_____	M1-8-8-N1
10	1,5	_____	M1-10-8-N1
12	1,5	_____	M1-12-8-N1
16	1,5	_____	M1-16-8-N1
20	2,0	_____	M1-20-8-N1
25	2,0	_____	M1-25-8-N1
32	2,2	_____	M1-32-8-N1
40a	2,8	_____	M1-40a-8-N1
40	3,0	_____	M1-40-8-N1
50	3,5	_____	M1-50-8-N1

J1 Series Component 8 for pressures up to PN 100:

DN	h_3	d_2	Order number
4	1,5	_____	J1-4-8-N1
6	1,5	_____	J1-6-8-N1
8	1,5	_____	J1-8-8-N1
10	2	_____	J1-10-8-N1
12	2	_____	J1-12-8-N1
16	2	_____	J1-16-8-N1
20	2	_____	J1-20-8-N1
25	2,2	_____	J1-25-8-N1
32	3,5	_____	J1-32-8-N1
40	3,5	_____	J1-40-8-N1
50	3,5	_____	J1-50-8-N1

M2 Series Component 8 for pressures up to PN 200:

DN	h_3	d_2	Order number
3	1,5	_____	M2-3-8-N1
4	1,5	_____	M2-4-8-N1
6	1,5	_____	M2-6-8-N1
8	2	_____	M2-8-8-N1
10	2	_____	M2-10-8-N1
12	2	_____	M2-12-8-N1
16	2	_____	M2-16-8-N1
20	2,5	_____	M2-20-8-N1
25	3	_____	M2-25-8-N1
32	3,5	_____	M2-32-8-N1
40	3,9	_____	M2-40-8-N1
50	4,7	_____	M2-50-8-N1

J2 Series Component 8 for pressures up to PN 250:

DN	h_3	d_2	Order number
3	1,5	_____	J2-3-8-N1
4	1,5	_____	J2-4-8-N1
6	1,5	_____	J2-6-8-N1
8	2	_____	J2-8-8-N1
10	2	_____	J2-10-8-N1
12	2	_____	J2-12-8-N1
16	2	_____	J2-16-8-N1
20	2,5	_____	J2-20-8-N1
25	3	_____	J2-25-8-N1
32	3,5	_____	J2-32-8-N1
40	5	_____	J2-40-8-N1

Please indicate the required boring diameter!

M3 Series Component 8 for pressures up to PN 320:

DN	h ₃	d ₂	Order number
3	1,5	_____	M3-3-8-N1
4	1,5	_____	M3-4-8-N1
5	2	_____	M3-5-8-N1
6	2,5	_____	M3-6-8-N1
8	2,5	_____	M3-8-8-N1
10	3	_____	M3-10-8-N1
12	3	_____	M3-12-8-N1
16	3,5	_____	M3-16-8-N1
20	4	_____	M3-20-8-N1
25a	4,5	_____	M3-25a-8-N1
25	4,5	_____	M3-25-8-N1
32	5	_____	M3-32-8-N1

J3 Series Component 8 for pressures up to PN 320:

DN	h ₃	d ₂	Order number
3	1,5	_____	J3-3-8-N1
4	1,5	_____	J3-4-8-N1
5	2	_____	J3-5-8-N1
6	2,5	_____	J3-6-8-N1
8	2,5	_____	J3-8-8-N1
10	3	_____	J3-10-8-N1
12	3	_____	J3-12-8-N1
16	3,5	_____	J3-16-8-N1
20	4	_____	J3-20-8-N1
25	4,5	_____	J3-25-8-N1
32	5	_____	J3-32-8-N1

Material:

Material number acc. to DIN	Material specification	AISI material specification	DILO material code letter
1.4571	X6CrNiMoTi17-12-2	316Ti	C
1.4922	X20CrMoV11-1	---	Q

High-pressure hoses



DILO high pressure hoses are the right solution for liquids and applicable for high pressure use. The hoses withstand pressures of up to PN 320 without any problems.

■ **High-pressure hoses**

76

High-pressure hoses



■ Range of temperature from -40 °C to +100 °C (see DIN EN 853/856)

■ All hoses are vacuum-tight.

■ **Materials and composition**

The hoses consist of an internal layer made of synthetic rubber which is oil- and water-proof and of an external rubber layer which is oil- and weatherproof.
Rubber hose reinforced with wire braid.

■ **Fitting material**

Standard: DIN EN material number 1.0460.
DIN EN material number 1.4571 on request.
The hose fitting is made in pressnipple form.

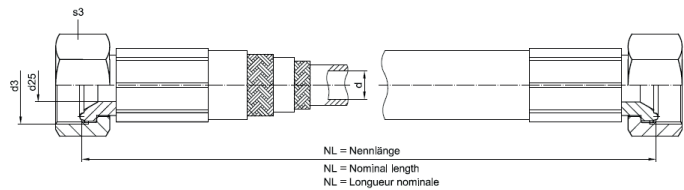

■ Application only for liquids

Ordering example: M1 S 10 L00450 A

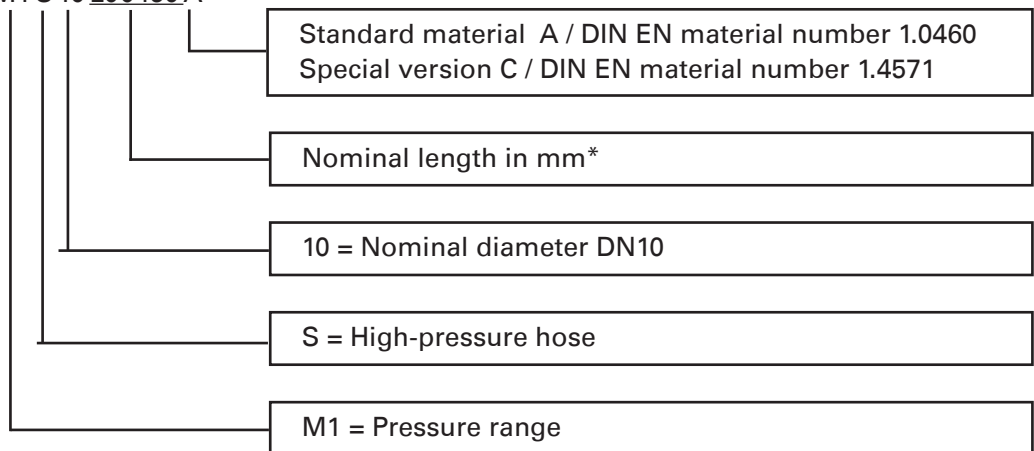

*High-pressure hoses are available in the following length increments:

Length	Length increment	Tolerance
< 1 m	50 mm	± 2 %
1 m to < 5 m	100 mm	
5 m to < 10 m	500 mm	± 1 %
10 m to < 20 m	1 m	

M1HDS Series for pressures up to PN 100:

DN	d	d ₂₅ *	d ₃	s ₃	Banding radius	Order number**
8	6,4	4	M 18x1,5	22	100	M1S8L
10	7,9	5,5	M 20x1,5	24	115	M1S10L
12	9,5	7	M 22x1,5	27	130	M1S12L
16	12,7	10	M 26x1,5	32	180	M1S16L
20	15,9	13	M 30x1,5	36	200	M1S20L
25	19	15,5	M 36x2	41	240	M1S25L
32	25,4	21	M 45x2	50	300	M1S32L
40	38,1	32	M 56x2	65	560	M1S40L
50	50,8	42	M 68x2	75	710	M1S50L

J1HDS Series for pressures up to PN 100:

DN	d	d ₂₅ *	d ₃	s ₃	Banding radius	Order number**
8	6,4	4	M 18x1,5	22	100	J1S8L
10	9,5	7	M 22x1,5	27	130	J1S10L
12	12,7	10	M 24x1,5	30	180	J1S12L
16	15,9	13	M 30x2	36	200	J1S16L
20	19	15,5	M 36x2	41	140	J1S20L
25	25,4	21	M 45x2	50	300	J1S25L
32	31,8	27	M 52x2	60	420	J1S32L
40	38,1	32	M 60x2	70	560	J1S40L
50	50,8	42	M 72x2	80	710	J1S50L

M2HDS Series for pressures up to PN 200:

DN	d	d ₂₅ *	d ₃	s ₃	Banding radius	Order number**
6	6,4	4	M 18x1,5	22	100	M2S6L
8	7,9	5,5	M 20x1,5	24	115	M2S8L
10	9,5	7	M 22x1,5	27	130	M2S10L
12	12,7	10	M 24x1,5	30	180	M2S12L
16	15,9	13	M 30x2	36	200	M2S16L
20	19	15,5	M 36x2	46	240	M2S20L
25	25,4	21	M 42x2	50	350	M2S25L
32	31,8	27	M 52x2	60	460	M2S32L
40	38,1	32	M 56x2	65	560	M2S40L
50	50,8	42	M 68x2	80	710	M2S50L

* Smallest diameter of the hose fitting.

** When ordering please specify the desired nominal length.

High-pressure hoses

J2HDS Series for pressures up to PN 250:

DN	d	d ₂₅ *	d ₃	s ₃	Banding radius	Order number**
6	6,4	4	M 18x1,5	22	100	J2S6L
8	7,9	5,5	M 20x1,5	24	115	J2S8L
10	9,5	7	M 22x1,5	27	130	J2S10L
12	12,7	10	M 24x1,5	30	180	J2S12L
16	15,9	13	M 30x2	36	200	J2S16L
20 (215 bar)	19	15,5	M 36x2	46	240	J2S20L
25	25,4	21	M 45x2	55	350	J2S25L
32	31,8	27	M 52x2	60	460	J2S32L
40 (200 bar)	38,1	32	M 64x2	75	560	J2S40L

M3HDS Series for pressures up to PN 320:

DN	d	d ₂₅ *	d ₃	s ₃	Banding radius	Order number**
5	6,4	4	M 18x1,5	24	100	M3S5L
6	7,9	5,5	M 20x1,5	27	115	M3S6L
8	9,5	7	M 22x1,5	30	130	M3S8L
10	12,7	10	M 24x1,5	32	190	M3S10L
12	15,9	13	M 30x2	36	200	M3S12L
16	19	15	M 36x2	46	280	M3S16L
20	25,4	20	M 42x2	50	350	M3S20L

J3HDS Series for pressures up to PN 320:

DN	d	d ₂₅ *	d ₃	s ₃	Banding radius	Order number**
4	6,4	3	M 16x1,5	22	90	J3S4L
5	6,4	4	M 18x1,5	24	100	J3S5L
6	7,9	5,5	M 20x1,5	27	115	J3S6L
8	9,5	7	M 22x1,5	30	130	J3S8L
10	12,7	10	M 27x2	36	190	J3S10L
12	15,9	13	M 33x2	41	200	J3S12L
16	19	15	M 39x2	46	280	J3S16L
20	25,4	21	M 48x2	55	350	J3S20L

* Smallest diameter of the hose fitting.

** When ordering please specify the desired nominal length.

Material:

Material number acc. to DIN	Material specification	AISI material specification	DILO material code letter
1.0460	P250GH	1022M	A
1.4571	X6CrNiMoTi17-12-2	316 Ti	C

DILO soldering unions



DILO soldering unions are particularly used in factory fabrication area piping. DILO offers a very wide variety of unions. Soldering unions are available either with soldering connections on both ends where the highest vibration resistance is required or with a soldering connection on one end and a screw in thread on the other.

DILO soldering unions withstand pressures up to 64 bar.

Different materials are available for all applications.

The suitable connecting parts for DILO couplings must be ordered separately.

■ DILO soldering unions of the ML1 series for pressures up to PN64

■ ML1A-AD	Soldering stub-soldering union PN64	86
■ ML1BO-AD	Screw-in stub-soldering union PN64 with O-ring	87
■ ML1M-AD10	Gauge union PN64 DN8	88
■ 3-328-R020	Gauge union PN64 DN8	89
■ ML1-..8	Blanking disk PN64	90
■ VST03	Plug PN64	90
■ 05-1545-R...	Tee piece	91
■ 05-1545-R...	Angle piece	91
■ 05-1545-R...	Plug-in angle piece	92

PN64

Soldering stub-soldering union

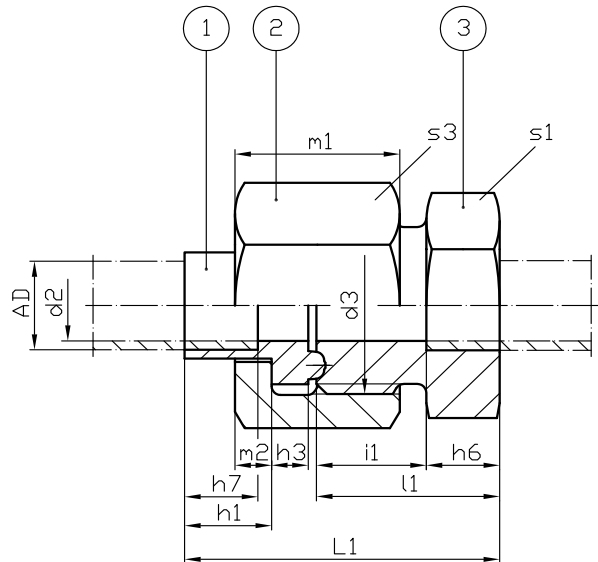
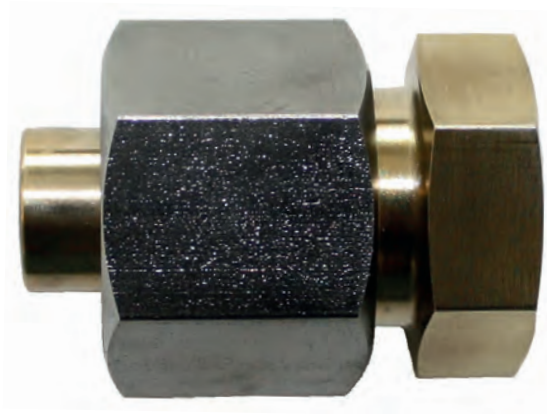

Tube outside diameter Ø AD	d2	d3	L1	l1	h1	h3	h6	h7	m1	m2	i1	s1	s3	Order No.
10	8	M20x1,5	35	20	9,5	4	8	8	18	4	12	22	24	ML1A-AD10 P
10	8	M20x1,5	35	20	9,5	4	8	8	18	4	12	22	24	ML1A-AD10 C
15	12	M26x1,5	52	22	13,5	5	10	10	20	5	12	27	32	ML1A-AD15 P
22	19	M36x2	54	31	15,5	6	12	12	26	7	16	41	41	ML1A-AD22 P
22	19	M36x2	54	31	15,5	6	12	12	26	7	16	41	41	ML1A-AD22 C
42	35	M56x2	65	37	19,5	7	20	20	29	7	18	60	65	ML1A-AD42 P
42	35	M56x2	65	37	19,5	7	20	20	29	7	18	60	65	ML1A-AD42 C

Piece	Designation	Order No.	Material
1	Soldering shoulder-tongue part	ML1-AD_____-1	P = Brass / C = Stainless steel
2	Clamping nut	ML1-AD_____-2	P = Brass / C = Stainless steel
3	Soldering stub-groove part	ML1-AD_____-3	P = Brass / C = Stainless steel

Note: For the nominal width (outside diameter 10) the clamping nut is made of stainless steel.

PN64

Screw-in stub-soldering union with O-ring

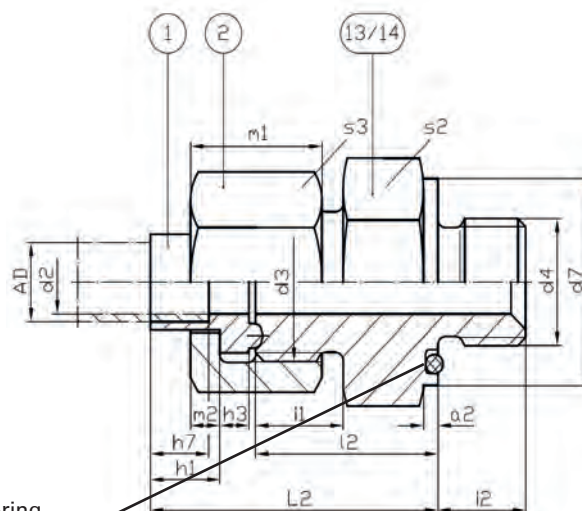
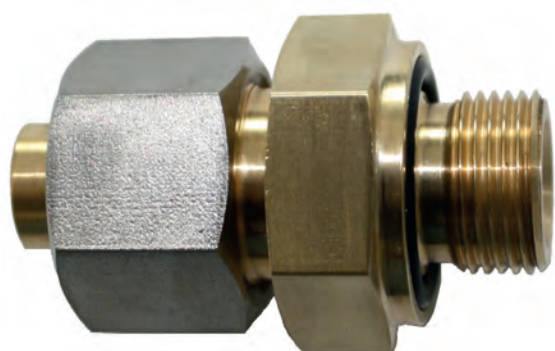

Spare O-ring
 Order No. AD10: 05-0057-R016
 AD15: 05-0057-R087
 AD22: 05-0057-R039
 AD42: 05-0057-R126

Tube outside diameter Ø AD	d2	d3	d4	d7	L2	l2	h1	h3	h7	m1	m2	i1	i2	a2	s2	s3	Order No.
10	8	M20x1,5	M16x1,5	26	40	25	9,5	4	8	18	4	12	12	2	27	24	ML1BO-AD10 P
10	8	M20x1,5	M16x1,5	26	40	25	9,5	4	8	18	4	12	12	2	27	24	ML1BO-AD10T
10	8	M20x1,5	G 3/8 A	26	40	25	9,5	4	8	18	4	12	12	2	27	24	ML1BO-AD10G P
10	8	M20x1,5	G 3/8 A	26	40	25	9,5	4	8	18	4	12	12	2	27	24	ML1BO-AD10GT
15	12	M26x1,5	G 1/2 A	32	47	27	13,5	5	10	20	5	12	14	3	32	32	ML1BO-AD15G P
22	19	M36x2	M33x2	49	59	36	15,5	6	12	26	7	16	18	3	50	41	ML1BO-AD22 P
22	19	M36x2	M33x2	49	59	36	15,5	6	12	26	7	16	18	3	50	41	ML1BO-AD22T
22	19	M36x2	G 1 A	49	59	36	15,5	6	12	26	7	16	18	3	50	41	ML1BO-AD22G P
22	19	M36x2	G 1 A	49	59	36	15,5	6	12	26	7	16	18	3	50	41	ML1BO-AD22GT
42	35	M56x2	G 1 1/2 A	65	69	41	19,5	7	20	29	7	18	22	3	65	65	ML1BO-AD42G P

Piece	Designation	Order No.	Material
1	Soldering shoulder-tongue part	ML1-AD_____-1	P = Brass / C = Stainless steel
2	Clamping nut	ML1-AD_____-2	P = Brass / C = Stainless steel
13	Screw-in stub (M16x1,5 / M33x2)	ML1-AD_____-13	P = Brass / T = AL
14	Screw-in stub (G 3/8 A / G 1/2 A / G 1 A / G 1 1/2 A)	ML1-AD_____-14	P = Brass / T = AL

Note: For the nominal width (outside diameter 10) the clamping nut is made of stainless steel. Regarding material AL only part 13 or 14 is made of AL, part 1 and 2 are made of stainless steel.

In special version the screw-in thread can also be supplied with sealing edge according to DIN 3852-1 and DIN EN ISO 1179.

PN64 DN8

Gauge union

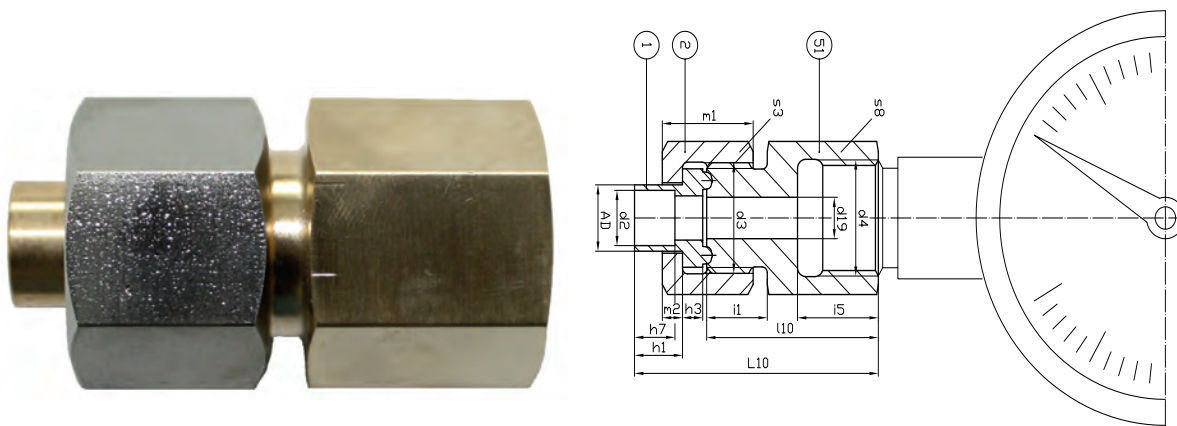

Tube outside diameter Ø AD	d2	d3	d4	d19	L10	l10	h1	h3	h7	m1	m2	i1	i5	s3	s8	Order No.
10	8	M20x1,5	G 1/2	7,5	49	34	9,5	4	8	18	4	12	16	24	24	ML1M-AD10/51
10	8	M20x1,5	G 1/4	5,5	44	29	9,5	4	8	18	4	12	13	24	22	ML1M-AD10/59

Piece	Designation	Order No.	Material
1	Soldering shoulder-tongue part	ML1-AD10-1 P	Brass
2	Clamping nut	ML1-AD10-2 C	Stainless steel
3	Gauge connecting piece	M1-10-51 P	Brass
3	Gauge connecting piece	M1-10-59 P	Brass

PN64 DN8
Gauge union

Order No.: 3-328-R020 P
Material: Brass

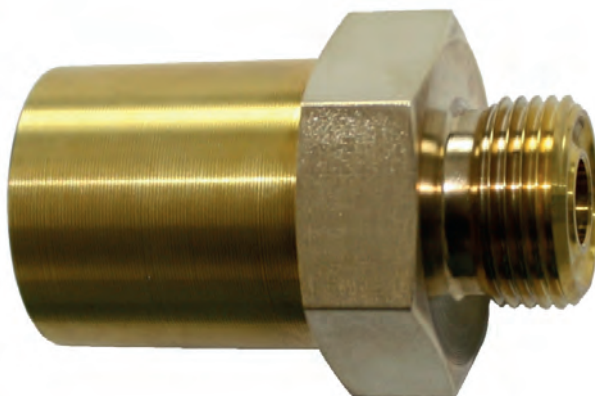

Suitable connecting parts

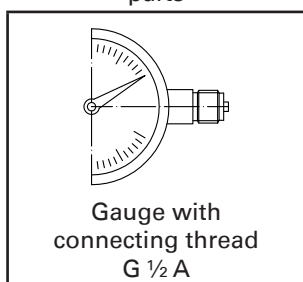

Suitable connecting parts

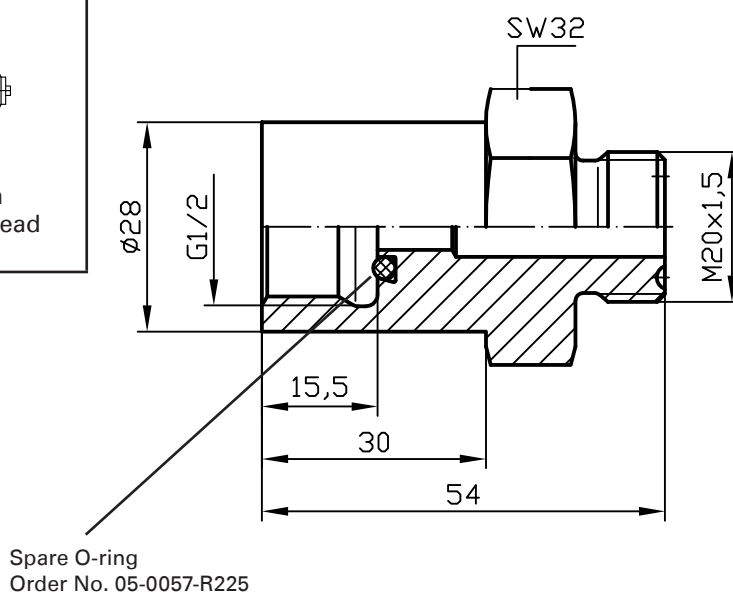
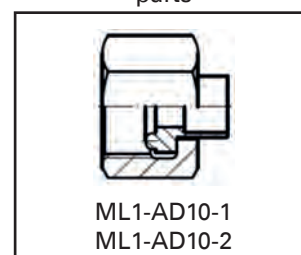

PN64

Blanking disk

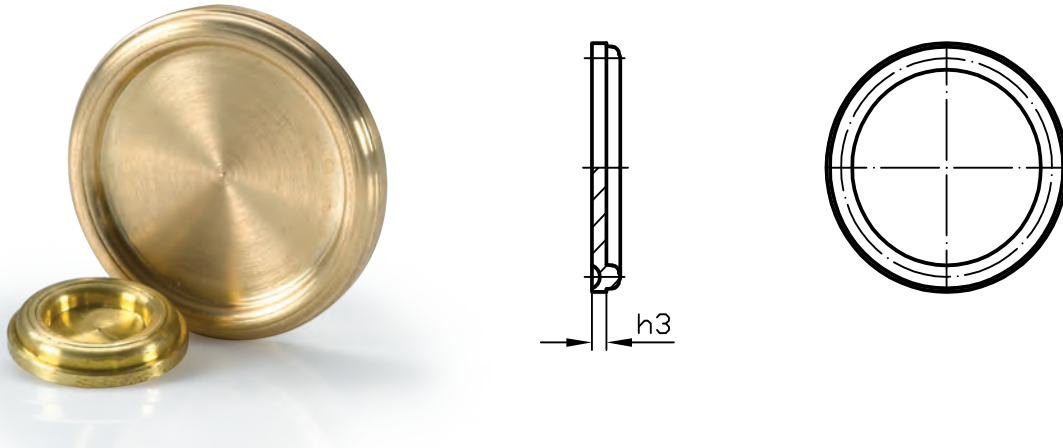

Tube outside diameter \varnothing AD	h3	Order No.	Material
10	1,5	ML1-10-8 P	Brass
22	2	ML1-22-8 P	Brass
42	3	ML1-42-8 P	Brass

PN64

Plug

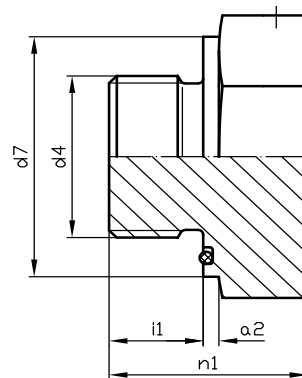

Metric fine thread ISO						Whitworth pipe thread			Spare O-ring		
d4	d7	n1	i1	a2	s2	Order No.	Material	d4	Order No.	Material	Order No.
	23	23	12	2	24			G 1/4 A	VST03 / G 1/4 AT	AL	05-0057-R088
M16x1,5	26	24	12	2	27	VST03 / M16x1,5	AL	G 3/8 A	VST03 / G 3/8 AT	AL	05-0057-R016
	36	32	15	3	36			G 1/2 A	VST03 / G 1/2 AT	AL	05-0057-R033
M33x2	49	38	18	3	50	VST03 / M33x2T	AL	G 1 A	VST03 / G 1 AT	AL	05-0057-R039
	65	45	22	3	65			G 1 1/2 A	VST03 / G 1 1/2 AT	AL	05-0057-R126

Tee piece

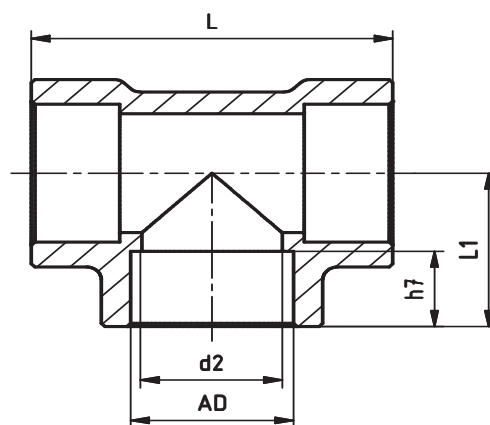

Tube outside diameter \varnothing AD	PN	d2	L	L1	h7	Order No.	Material
10	64	8	29	14,5	8	05-1545-R001	Brass
15	64	12	38	19	10	05-1545-R004	Brass
22	64	19	49	24,5	12	05-1545-R002	Brass
42	25	39	90	45	20	05-1545-R003	Brass

Angle piece

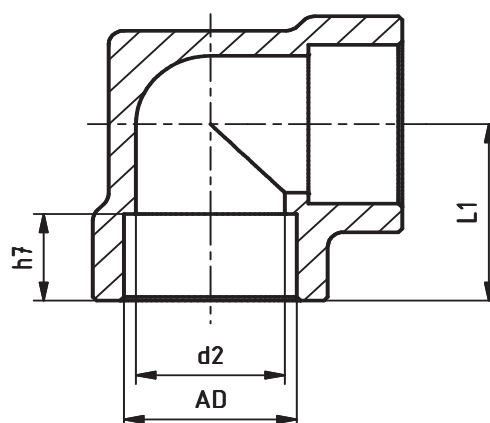

Tube outside diameter \varnothing AD	PN	d2	L1	h7	Order No.	Material
10	64	8	14,5	8	05-1545-R005	Brass
15	64	12	19	10	05-1545-R008	Brass
22	64	19	24,5	12	05-1545-R006	Brass
42	25	39	45	20	05-1545-R007	Brass

Plug-in angle piece

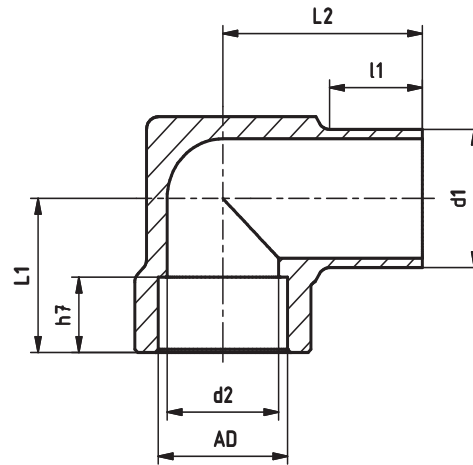

Tube outside diameter Ø AD	PN	d2	L1	h7	L2	d1	l1	Order No.	Material
10	64	8	14,5	8	21,5	10	10	05-1545-R010	Brass
15	64	12	19	10	26	15	13	05-1545-R011	Brass
22	64	19	24,5	12	34	22	16	05-1545-R012	Brass
42	25	39	45	20	56,4	42	24	05-1545-R013	Brass



For your notes



SF₆ gas handling

SF₆ gas handling is DILO's second core competence.
For further information please ask for our special leaflet.

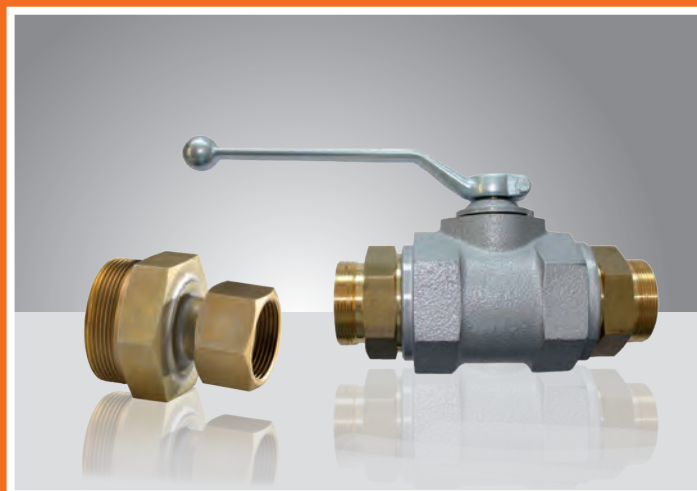

Valves and connections for SF₆-Gas

DILO
Armaturen und Anlagen GmbH

Frundsbergstrasse 36
D-87727 Babenhausen

Phone: + 49 (0) 83 33 - 302-0
Fax: + 49 (0) 83 33 - 302-52
E-Mail: info@dilo-gmbh.com